



Humboldt County Onsite Wastewater Local Agency Management Program

Adopted by the Humboldt County Board of Supervisors

Virginia Bass, Chair
Humboldt County Board of Supervisors

Date: _____

**Humboldt County
Onsite Wastewater Local Agency Management Program**

Table of Contents

Introduction	1
Responsibilities and Duties	2
OWTS Owners’ Responsibilities and Duties.....	2
Local Agency Requirements and Responsibilities	3
Withdrawal of LAMP	4
Tier 0 – Existing OWTS	4
Coverage for Properly Operating Existing OWTS	5
Tier 2 – Local Agency OWTS Management Program	5
Local Agency Management Program for Minimum OWTS Standards.....	5
Features and Conditions Not Allowed to be Authorized in LAMP.....	14
Tier 3 - Advanced Protection Management Program for Impaired Areas	16
Special Provisions	18
Criteria for New Construction OWTS Within APMP	19
Criteria for Repairs to OWTS Within APMP	19
Table 1 – Variance Prohibition Areas	20
Figures 1 - 5	21 - 25
Tier 4 – OWTS Requiring Corrective Action	26
Appendix 1: Humboldt County Onsite Wastewater Regulations and Technical Manual	
Appendix 2: Humboldt County Code Title VI Division 1 and Division 2	
Appendix 3: SWRCB <i>Water Quality Control Policy for Siting, Design, Operation, and Maintenance of Onsite Wastewater Treatment Systems.</i>	

Humboldt County Onsite Wastewater Local Agency Management Program

Introduction

Purpose

This Local Agency Management Program (LAMP) is prepared pursuant to, and describes Humboldt County's compliance with, the State Water Resources Control Board's *Water Quality Control Policy for Siting, Design, Operation, and Maintenance of Onsite Wastewater Treatment Systems* (OWTS Policy). When approved by the North Coast Regional Water Quality Control Board (NCRWQCB) and the Humboldt County Board of Supervisors, it (along with supporting local documents *Humboldt County Onsite Wastewater Treatment System Regulation and Technical Manual* (RTM) and Humboldt County Code, Title VI, Divisions 1 and 2 (HCC)) will be formally adopted and implemented in the unincorporated area of Humboldt County.

The purpose of the OWTS Policy and this LAMP is to allow for the continued use of onsite wastewater treatment systems (OWTS) in a manner that protects water quality and public health. OWTS owners in Humboldt County who comply with this LAMP are included in a conditional waiver to apply for Waste Discharge Requirements through the NCRWQCB for their OWTS.

The Humboldt County Board of Supervisors (BOS) has opted to pursue development and implementation of a LAMP in accordance with, and as authorized in, Tier 2 of the OWTS Policy. The Department of Health and Human Services, Division of Environmental Health (DEH), is the authority for permitting OWTS and implementing this LAMP. This LAMP addresses the siting, design, operation and maintenance of OWTS that:

- Have a projected flow of 10,000 gallons per day or less; and
- Receive only domestic wastewater from residential or commercial buildings; or
- Receive high strength wastewater that does not exceed 900 mg/L Biological Oxygen Demand (BOD) from commercial food service buildings which have a properly sized and functioning oil/grease interceptor.

Humboldt County is within Region 1, the North Coast Regional Water Quality Control Board jurisdiction.

Structure

The OWTS Policy requirements (complete or summarized as necessary) are presented with their section number and appear in bold text for easy reference throughout the LAMP (*e.g.*, **9.1.1 Degree of vulnerability to pollution from OWTS due to hydrogeological conditions**). They appear generally in the order in which they appear in the OWTS Policy. The text below each of these entries, in normal font, describes Humboldt County's method of compliance with that OWTS Policy section.

References to Tiers 0, 1, 2, 3 and 4 refer to the Tiers specified in the OWTS Policy.

The RTM is included for reference as Appendix 1. The RTM is a new document and replaces the former *Humboldt County Sewage Disposal Regulations*. The RTM incorporates policies and practices from several documents (*Humboldt County Sewage Disposal Regulations*, technical design manuals, and the Regional Water Board's *Basin Plan*) into one document with updated language and a user-friendly format.

The portion of the HCC applicable to OWTS management (Title VI, Division 1) and septage pumper regulation (Title VI, Division 2) is included for reference as Appendix 2.

The OWTS Policy (via electronic link) is included for reference as Appendix 3.

Responsibilities and Duties

2.0 OWTS Owners' Responsibilities and Duties

The most important aspect of managing an OWTS is good stewardship on the part of the OWTS owner. Section 2.0 of the OWTS Policy assigns responsibilities and duties to OWTS owners. Sections 2.1 – 2.7 are reproduced here as they appear in the OWTS Policy; they apply to all OWTS owners in Humboldt County.

2.1 All new, replacement, or existing OWTS within an area that is subject to a Basin Plan prohibition of discharges from OWTS, must comply with the prohibition. If the prohibition authorizes discharges under specified conditions, the discharge must comply with those conditions and the applicable provisions of this Policy.

2.2 Owners of OWTS shall adhere to the requirements prescribed in local codes and ordinances. Owners of new and replacement OWTS covered by this Policy shall also meet the minimum standards contained in Tier 1, or an alternate standard provided by a Local Agency Management Program per Tier 2, or shall comply with the requirements of Tier 3 if near an impaired water body and subject to Tier 3, or shall provide corrective action for their OWTS if their system meets conditions that place it in Tier 4.

2.3 Owners of OWTS shall comply with any and all permitting conditions imposed by a local agency that do not directly conflict with this Policy, including any conditions that are more stringent than required by this Policy.

2.4 To receive coverage under this Policy and the included waiver of waste discharges, OWTS shall only accept and treat flows of domestic wastewater. In addition, OWTS that accept high-strength wastewater from commercial food service buildings are covered under this Policy and the waiver of waste discharge requirements if the wastewater does not exceed 900 mg/L BOD and there is a properly sized and functioning oil/grease interceptor (a.k.a. grease trap).

2.5 Owners of OWTS shall maintain their OWTS in good working condition including inspections and pumping of solids as necessary, or as required by local ordinances, to maintain proper function and assure adequate treatment.

2.6 The following owners of OWTS shall notify the Regional Water Board by submitting a Report of Waste Discharge for the following:

2.6.1 a new or replacement OWTS that does not meet the conditions and requirements set forth in either a Local Agency Management Program if one is approved, an existing local program if it is less than 60 months from the effective date of the Policy and a Local Agency Management Program is not yet approved, or Tier 1 if no Local Agency Management Program has been approved and it is more than 60 months after the effective date of this Policy;

2.6.2 any OWTS, not under individual waste discharge requirements or a waiver of individual waste discharge requirements issued by a Regional Water Board, with the projected flow of over 10,000 gallons-per-day;

2.6.3 any OWTS that receives high-strength wastewater, unless the waste stream is from a commercial food service building;

2.6.4 any OWTS that receives high-strength wastewater from a commercial food service building: (1) with a BOD higher than 900 mg/L, or (2) that does not have a properly sized and functioning oil/grease interceptor.

2.7 All Reports of Waste Discharge shall be accompanied by the required application fee pursuant to California Code of Regulations, title 23, section 2200.

3.0 Local Agency Requirements and Responsibilities

Humboldt County implements this LAMP to regulate the siting, design, operation and maintenance of OWTS as authorized in Tier 2 of the OWTS Policy. DEH is the authority for permitting OWTS and implementing this LAMP.

3.3 Annual Report

DEH will submit an annual report in tabular spreadsheet format that provides the following information by February 1st of each year to the NCRWQCB:

3.3.1 The number and location of complaints pertaining to OWTS operations and maintenance, and identification of those which were investigated and how they were resolved;

3.3.2 Applications and registrations issued to septic tank cleaning businesses pursuant to Section 117400 et seq. of the California Health and Safety Code;

3.3.3 The number, location, and description of permits issued for new and replacement OWTS and under which Tier each permit was issued.

9.3.1 The number, location, and description of permits issued for OWTS where a variance was granted.

3.4 Permanent Records

DEH will maintain permanent records for all OWTS permitting actions and will make those records available within 10 working days upon written request for review by the NCRWQCB. The records for each permit will reference the Tier under which the permit was issued.

3.5 Notification to water providers of OWTS failure

DEH will notify the owner of a public water well or water intake and the State Water Resources Control Board Drinking Water Program as soon as practicable, but no later than 72 hours upon its discovery, of a failing OWTS as described in OWTS Policy sections 11.1 and 11.2 occurring within the following setbacks:

7.5.6 150 feet from a public water well where the depth of the effluent dispersal field does not exceed 10 feet.

7.5.7 Within 1,200 feet from a public water system surface water intake if the failing system is 400 feet or less from the high water mark of the water body.

7.5.8 Within 2,500 feet from a public water system surface intake if the failing system is less than 200 feet from the high water mark of the water body.

All public water system wells and surface water intake locations will be mapped. The distances shown above will be delineated around each well and surface water intake. Upon discovery of a failing OWTS, DEH will reference this map and notify water system owners as required.

3.8 Withdrawal of LAMP

If Humboldt County wishes to withdraw a previously submitted and approved LAMP, it may do so upon 60 days written notice to the NCRWQCB. The notice of withdrawal shall specify the reason for withdrawing its Tier 2 program, the effective date for the cessation of the program, and the resumption of permitting of OWTS only under Tiers 0, 1, 3 and 4.

Tier 0 – Existing OWTS

Existing OWTS that are properly functioning and do not meet the conditions of failing systems or otherwise require corrective action (for example, to prevent groundwater impairment), as specifically described in Tier 4, and are not determined to be contributing to an impairment of surface water, as specifically described in Tier 3, are automatically included in Tier 0.

6.0 Coverage for Properly Operating Existing OWTS

6.1 Existing OWTS are automatically covered by Tier 0 and the herein included waiver of waste discharge requirements if they meet the following requirements:

6.1.1 have a projected flow of 10,000 gallons-per-day or less;

6.1.2 receive only domestic wastewater from residential or commercial buildings, or high-strength wastewater from commercial food service buildings that does not exceed 900 mg/L BOD and has a properly sized and functioning oil/grease interceptor (a.k.a. grease trap);

6.1.3 continue to comply with any previously imposed permitting conditions;

6.1.4 do not require supplemental treatment under Tier 3;

6.1.5 do not require corrective action under Tier 4; and

6.1.6 do not consist of a cesspool as a means of wastewater disposal.

6.2 A Regional Water Board or local agency may deny coverage under this Policy to any OWTS that is:

6.2.1 Not in compliance with Section 6.1;

6.2.2 Not able to adequately protect the water quality of the waters of the State, as determined by the Regional Water Board after considering any input from the local agency. A Regional Water Board may require the submission of a report of waste discharge to receive Region specific waste discharge requirements or waiver of waste discharge requirements so as to be protective.

6.3 Existing OWTS currently under waste discharge requirements or individual waiver of waste discharge requirements will remain under those orders until notified in writing by the appropriate Regional Water Board that they are covered under this Policy.

Tier 2 – Local Agency OWTS Management Program

9.0 Local Agency Management Program for Minimum OWTS Standards

Humboldt County's physical and human geography present a number of constraints that prohibit the implementation of the OWTS Policy's Tier 1 standards. Humboldt County's option for compliance is the adoption and implementation of this Tier 2 LAMP. It sets forth minimum standards which differ from Tier 1 but still achieve the OWTS Policy's purpose: to allow the continued use of OWTS while protecting water quality and public health.

Challenging conditions considered in LAMP development and the methods Humboldt County employs to protect water quality and public health are shown below.

9.1.1 Degree of vulnerability to pollution from OWTS due to hydrogeological conditions.

9.1.2 High Quality waters or other environmental conditions requiring enhanced protection from the effects of OWTS.

9.1.3 Shallow soils requiring a dispersal system installation that is closer to the ground surface than is standard.

9.1.4 High domestic well usage.

9.1.5 Dispersal system is located in an area with fractured bedrock.

9.1.6 Dispersal System is located in an area with poorly drained soils.

9.1.7 Vulnerable surface water.

With approximately half its households dependent on onsite wastewater treatment, Humboldt County has approximately 17,000 OWTS within its jurisdiction. Using its Sewage Disposal Regulations, the Regional Waster Board's Basin Plan, and local policies and practices, DEH has been responding to proposals for OWTS new construction, modifications, and repairs in areas with challenging conditions such as those listed in OWTS Policy sections **9.1.1 – 9.1.12** (with the exception of 9.1.8). DEH began in 1980 to permit OWTS installations only after soils testing and groundwater level determinations had been performed. Because many areas of the County exhibit shallow groundwater and restrictive soils, they are not suitable to the use of standard OWTS (those relying solely on gravity to disperse effluent). Thus, in the 1980s, DEH began to permit the installation of non-standard OWTS (those which rely on pressure distribution of effluent) (NSOWTS) because, on many sites, groundwater quality and public health cannot be protected with standard gravity systems.

The siting and design requirements of Humboldt County's RTM call for qualified professionals to perform site evaluations to determine the soil, groundwater, and physical restrictions which exist on a site and to propose an OWTS design which will support the wastewater needs of the site structures. When properly implemented, the siting and design requirements, along with construction oversight and OWTS monitoring, achieve the OWTS Policy purpose of protecting water quality and public health.

Table 1, Variance Prohibition Areas (see page 20) identifies areas in Humboldt County known to exhibit one or more of the challenging conditions listed in OWTS Policy section **9.1** and shows mitigation measures employed. These areas are specifically addressed in the RTM on page 3. Mitigation measures for new OWTS construction proposed in the areas listed in Table 1 include:

- Wet weather testing (wet weather groundwater monitoring and percolation testing) is required in all areas listed on Table 1; and
- No variances to siting and design standards will be considered

9.1.8 Surface water within the watershed is listed as impaired for nitrogen or pathogens.

This is further addressed on page 16 under Tier 3.

9.1.9 OWTS is located within an area of high OWTS density.

The following communities in Humboldt County contain areas of high OWTS density:

- Fairhaven
- Pacific Manor Subdivision (west of Arcata)
- Portions of Hydesville and Carlotta, in the Van Duzen Hydrologic Unit

Fairhaven

The community of Fairhaven has a high OWTS density along with a number of small undeveloped parcels. Proposals for future development are subject, as part of the application process, to submittal of a Cumulative Impact Report assessing the groundwater mounding, organics and nitrogen impacts likely to occur due to the proposed development. HCC section 612-2(b)(3)(J) provides DEH the authority to require such information.

Pacific Manor

The Pacific Manor subdivision west of the City of Arcata boundary is another area with high OWTS density and small parcel sizes. These lots have already been developed and are further discussed following section 9.1.11 below.

Hydesville/Carlotta

Some areas of Hydesville and Carlotta in the Van Duzen Hydrologic Unit (HU) have a high OWTS density. The parcels that remain undeveloped, while they likely exhibit restrictive soils and will depend on onsite water supply, are typically large enough in size to support an OWTS and a replacement dispersal field.

9.1.10 A parcel's size and its susceptibility to hydraulic mounding, organic or nitrogen loading, and whether there is sufficient area for OWTS expansion in case of failure.

The creation of any new parcel in Humboldt County requires a qualified professional to demonstrate that all siting and design criteria in the RTM are met without a variance to any design criteria for both the primary and replacement dispersal areas. DEH staff receives these proposed projects for review from the Planning and Building Department and will recommend approval only when this is demonstrated satisfactorily. Typically, most rural lands where OWTS are used are created with minimum parcel sizes larger than those specified in Table 1 under Tier 1 of the OWTS Policy (See OWTS Policy page 22).

When development is proposed on existing undeveloped parcels outside the Variance Prohibition Areas, one or more variances may be considered by DEH staff during the design review. The OWTS application must identify which RTM standards are not met by the proposed design, must request a variance to each, and satisfactorily demonstrate that water quality will not be impaired

and that public health will not be threatened as a result of any variance. Variances to the standard requiring sufficient area for OWTS replacement will not be considered. Some parcels exist in Humboldt County that are not suitable to development.

Proposed developments, particularly subdivision developments, commercial establishments, and OWTS receiving greater than 1,500 gallons per day, are subject to groundwater mounding, organic and nitrogen study in the form of a Cumulative Impact Report. HCC section 611-12 provides the requirements for DEH review of subdivisions and lot line adjustments in non-sewered areas. HCC section 611-12(c) provides the County's Health Officer the authority to require a Cumulative Impact Study of the effects of wastewater discharge. DEH will consult with NCRWQCB staff on all these types of proposed projects and on any proposed project where it appears that a cumulative impact or other study is necessary to fully understanding the proposed project's impact.

9.1.11 Geographic areas that are known to have multiple, existing OWTS predating any adopted standards of design and construction including cesspools.

Existing OWTS are allowed to continue under Tier 0 until or unless a failure occurs. DEH will authorize repairs that are in substantial conformance, to the greatest extent practicable, with this LAMP and the RTM

Pacific Manor subdivision's lots and homes were constructed in the 1960s and 1970s using seepage pits. As failures occur in this area, DEH permits repairs and replacement OWTS to conform as closely as possible to current standards using NSOWTS.

Cesspools are deemed public nuisances pursuant to HCC section 613-2 and, when encountered, will be assigned a Tier 4 ranking (OWTS Requiring Corrective Action) and a replacement system, conforming as closely as possible to this LAMP and the RTM, will be required.

OWTS failures will be tracked, mapped, and reported to the NCRWQCB in annual reports.

Applications for permits to modify OWTS (expand capacity) are subject to the County's *Policy for the Use of Existing Onsite Wastewater Treatment Systems* (See RTM Appendix F).

9.1.12 Geographic areas that are known to have multiple, existing OWTS located within either the pertinent setbacks listed in Section 7.5 of the OWTS Policy, or a setback that the local agency finds is appropriate for that area.

The community of Alton has small parcels that were created prior to modern OWTS siting and design criteria. The parcels are served by private domestic wells which, in some cases, do not meet the 100 foot setback requirement to OWTS.

If, through the assessment and reporting requirements of the OWTS Policy or through any other means, DEH finds that its standards are not adequate to protect water quality and public health, additional protective measures will be considered and proposed in an amendment to this LAMP.

9.2 Scope of coverage, types of OWTS permitted, and local site evaluation, siting, design, and construction requirements.

The Humboldt County LAMP regulates domestic wastewater, as defined in the OWTS Policy, from residential or commercial buildings in the unincorporated areas of the County with daily flows not exceeding 10,000 gallons. High strength wastewater, as defined in the OWTS Policy, and wastewater from industrial processes are not regulated under this LAMP and remain the responsibility of the NCRWQCB. Parts 1, 2, and 4 of the RTM provide the types of OWTS permitted under the LAMP as well as local site evaluation, siting, design, and construction requirements.

9.2.1 Local agency requirements for onsite wastewater system inspection, monitoring, maintenance, and repairs, including procedures to ensure that replacements or repairs to failing systems are done under permit from the local governing jurisdiction.

Permits are required for new system installations and for modifications, repairs and destructions of existing systems. For permit requirements, see HCC section 612-2 and RTM Part 3.

Inspection requirements prior to and at the time of OWTS construction are found in the RTM on page 34. DEH maintains an operating permit and inspection program for NSOWTS. Each NSOWTS must undergo an inspection once every three years. The inspection must be performed by DEH or a Qualified Service Provider. Homeowners may conduct their own NSOWTS inspection upon approval by DEH. For inspection, monitoring, maintenance, and repair of non-standard systems, see HCC sections 616-1 and 616-3(a)(d)(g)(h)(i), and RTM at page 14.

9.2.2 Areas near impaired water bodies.

This is further addressed on page 16 under Tier 3.

9.2.3 Variances for new installations and repairs. Variances are not allowed for requirements stated in OWTS Policy sections 9.4.1 through 9.4.9.

A variance to any condition stated in section 9.4 of the OWTS policy (listed beginning on page 14 of this LAMP) will not be considered. Outside of Variance Prohibition Areas, variances requested to any standard contained in the RTM may be granted by DEH when it is demonstrated by the applicant that water quality will not be impaired and public health will not be threatened as a result of such variance. Variances for new construction or for modification are not allowed within the Variance Prohibition Area (*see* RTM at page 2).

For OWTS repairs in all areas of the County, DEH may authorize repairs that are in substantial conformance, to the greatest extent practicable, with this LAMP and the RTM. In some cases, this will require supplemental treatment.

DEH may consult with NCRWQCB staff prior to the issuance of any variance requested. A proposed variance from any standard requires submittal of a complete OWTS Variance Application and fee. Variances granted will be clearly stated on the permit and will be reported to NCRWQCB annually.

9.2.4 Educational, training, certification and/or licensing requirements that will be required of OWTS service providers, site evaluators, designers, installers, pumpers, maintenance contractors, and any other person related to OWTS activities.

See HCC section 611-2(n) for OWTS site evaluator and designer (Qualified Professional) qualification requirements.

See HCC section 616-2(d) for NSOWTS maintenance contractors' (Qualified Service Provider) qualification requirements.

OWTS installers must hold one of the following licenses: General Engineering Contractor, General Building Contractor, C-36 Plumbing Contractor or C-42 Sanitation System Contractor. *See* RTM at page 29.

See HCC Title VI Division 2 Sewage and Cesspool Cleaning for permit requirements for Septic Pumpers.

9.2.5 Educational and outreach program.

Community information sessions will be held soon after local adoption of the LAMP to educate the public on LAMP content and applicability. DEH has informational handouts available in hard copy and on its web page explaining how to properly operate and maintain various types of OWTS. Prior to LAMP implementation, DEH will ensure that all handouts are technically accurate yet reader-friendly. DEH will review this information and update it as necessary, but at a minimum, every five years in conjunction with the OWTS program evaluation required by OWTS Policy section 9.3.3.

Permits issued for NSOWTS following implementation of the LAMP will include homeowner procedures to ensure maintenance, repair, or replacement of critical items within 48 hours following failure.

Permits issued for NSOWTS utilizing supplemental treatment of effluent following implementation of the LAMP will require that an operation and maintenance agreement with a Qualified Service Provider, as defined in HCC section 616-2(d), be in force for the life of the system.

9.2.6 Assessment of existing and proposed disposal locations for septage, volume of septage anticipated and whether adequate capacity is available.

DEH maintains a registration and permit program for septic tank and grease trap pumpers. The permit application requires pumpers to report their disposal location(s). Currently, permitted pumpers dispose of their septage at the following locations:

1. City of Ferndale Sewer Treatment Facility
2. Trinity County Waterworks District #1
3. City of Eureka Sewer Treatment Facility
4. Steve's Septic Service (prior to discharge at McKinleyville Community Sewer Treatment Facility)

Pumpers are required to submit monthly records to DEH showing each pumping location and the location of septage disposed.

DEH will continue to collect data and will maintain communication with septage receiving facilities to determine the facilities' current and long term capacity to receive septage.

9.2.7 Onsite maintenance districts or zones.

Presently, there are no onsite wastewater districts in Humboldt County and no consideration was given to one in development of this LAMP.

9.2.8 Regional Salt and Nutrient Management Plans.

No consideration was given to development of such plans.

9.2.9 Coordination with watershed management groups.

There are several active watershed management groups in Humboldt County which were invited to participate in the LAMP development process. DEH will coordinate with Humboldt Baykeeper on the results of their surface water sampling program and will consider those results in its Advanced Protection Management Program (APMP) OWTS risk assessment. DEH will seek the input of local watershed management groups during future five-year water quality assessment reviews.

9.2.10 Evaluating the proximity of sewer systems to new or replacement OWTS installations.

DEH will maintain a mapped inventory of sewer areas. Public sewer authorities are consulted to provide the location of public sewer service when an application is reviewed by DEH and is shown to be near a sewer area. Sewer connection requirements will be initiated pursuant to HCC section 611-4.

9.2.11 Notifications to public water system.

All public water system wells, surface collection reservoirs, and surface water intakes locations will be mapped. Each OWTS application received will be compared to the map to determine if notifications must be made.

DEH will notify the owner of a public water system when an application is received for any new, replacement or repair OWTS where the OWTS is: (1) within 1,200 feet of an intake point for a surface water treatment plant providing drinking water, is in the drainage area catchment in which the intake point is located, and is located such that it may impact water quality at the intake point such as upstream of the intake point for a flowing water body; or (2) if the proposed OWTS is within the horizontal sanitary setback (150 feet) from a public well.

In accordance with the OWTS Policy, DEH will provide the following information to the owner of the public water system:

7.6.1 The permitting agency shall provide a copy of the permit application.

7.6.2 The permit application shall include a topographical plot plan for the parcel showing the OWTS components, the property boundaries, proposed structures, physical address, and name of property owner.

7.6.3 The permit application shall provide the estimated wastewater flows, intended use of proposed structure generating the wastewater, soil data, and estimated depth to seasonally saturated soils.

The public water system owner shall have 15 days from receipt of the permit application to provide recommendations and comments to DEH. If the owner of the public water system cannot be identified, DEH will notify the state agency having authority over the public water system (currently the State Water Resources Control Board Drinking Water Program).

9.2.12 Policies and procedures that will be followed when proposed OWTS dispersal area is within the horizontal sanitary setback of a public well or a surface water intake point.

Humboldt County DEH will consider proposed OWTS development within the required horizontal sanitary setback of a public well or surface water intake point on a case-by-case basis. A professional evaluation of site specific hydrogeological characteristics will be required; the evaluation must address potential contamination from proposed OWTS usage and propose the best available technology and siting practices to mitigate potential adverse effects to a public water source.

9.2.13 Cesspool usage.

Cesspools in Humboldt County are prohibited and are deemed public nuisances. (*See* HCC section 613-2). When discovered, DEH requires cesspools to be properly destroyed and a repair or replacement system installed as soon as practicable.

9.3 Minimum responsibilities of the local agency for management of the LAMP.

9.3.1 Maintain records of the number, location, and description of permits issued for OWTS where a variance is granted.

DEH maintains an electronic database with information on all OWTS permit applications received since 2010. The database will be configured to allow a search for permits where variances were granted after LAMP implementation.

9.3.2 Maintain a water quality assessment program to determine the general operation status of OWTS and evaluate the impact of OWTS discharges and assess the extent to which groundwater and surface water quality may be adversely impacted.

DEH has identified the areas exhibiting conditions listed in Section 9.1 of the OWTS Policy and listed them on Table 1 of this LAMP and in the RTM. These areas are most susceptible to water quality impacts. Other than the APMP areas (see Tier 3 at page 16), areas with individual water wells, small lots, and coarse soils, such as Alton and Carlotta, will receive first priority for monitoring and assessment.

OWTS failures, repairs, and water sample results exceeding drinking water and/or recreational water standards will be mapped for the purpose of determining the general operation status of OWTS, evaluating the impact of OWTS discharges, and assessing the extent to which groundwater and surface water quality may be adversely impacted.

Suspected water quality impacts from OWTS in these areas will be assessed through any or all of the following: complaint investigations, OWTS inspections, records research, surface water sampling, sanitary surveys, and, with the permission of well owners, DEH-collected water well and monitoring well samples. When such sampling is conducted, the samples will be analyzed for pathogens and nitrates. Water quality testing at the time of new well construction may be required, pursuant to HCC section 631-6(a) in priority areas.

DEH currently receives copies of laboratory analysis from the Public Health Laboratory of drinking water samples which show positive results for coliform bacteria. As part of the DEH investigation into the source of the positive coliform results, the existence and condition of an OWTS as a contributing factor is assessed. OWTS exhibiting a failure will be reclassified from its existing Tier to Tier 4, and will also require corrective action pursuant to Tier 4, the HCC, and the RTM.

Other data sources likely to be used include:

- Review of public water system sampling reports
- Beach water quality testing performed per Health & Safety Code Section 115885

- Surface water quality testing performed by DEH and/or others engaged in water quality studies in Humboldt County
- DEH complaint records
- Data contained in the California Water Quality Assessment Database
- Groundwater data collected as part of the Groundwater Ambient Monitoring and Assessment Program, available on the Geotracker Database.

9.3.3 Annual report of water quality assessment program. Every 5th year submit a monitoring program evaluation.

Included in the report due to the NCRWQCB by February 1st of each year, DEH will provide the number, location, and description of permits issued for OWTS where variances were granted. DEH will include a summary of monitoring data collected pursuant to 9.3.2 above. Groundwater monitoring data will be submitted in electronic deliverable format for inclusion into Geotracker; surface water monitoring data will be submitted to California Environmental Data Exchange Network (CEDEN) in a Surface Water Ambient Water Monitoring Program (SWAMP) comparable format. In addition to the annual report, an evaluation of the monitoring program will be submitted every 5th year identifying any changes in our LAMP that will be undertaken to address impacts from OWTS, along with an assessment of whether water quality is being impacted by OWTS. The first report will commence one year after NCRWQCB's approval of the LAMP.

Features and Conditions Not Allowed to be Authorized in LAMP.

Humboldt County LAMP will not authorize any of the conditions listed in Sections 9.4.1 through 9.4.12.

9.4 The following are not allowed to be authorized on a LAMP:

9.4.1 Cesspools of any kind or size.

9.4.2 OWTS receiving a projected flow over 10,000 gallons per day.

9.4.3 OWTS that utilize any form of effluent disposal that discharges on or above the post installation ground surface such as sprinklers, exposed drip lines, free-surface wetlands, or a pond.

9.4.4 Slopes greater than 30 percent without a slope stability report approved by a registered professional.

9.4.5 Decreased leaching area for IAPMO certified dispersal systems using a multiplier less than 0.70.

9.4.6 OWTS utilizing supplemental treatment without requirements for periodic monitoring or inspections.

9.4.7 OWTS dedicated to receiving significant amounts of wastes dumped from RV holding tanks.

9.4.8 Separation of the bottom of dispersal system to groundwater less than two (2) feet, except for seepage pits, which shall not be less than 10 feet.

9.4.9 Installation of new or replacement OWTS where public sewer is available. The public sewer may be considered as not available when such public sewer or any building or exterior drainage facility connected thereto is located more than 200 feet from any proposed building or exterior drainage facility on any lot or premises that abuts and is served by such public sewer. This provision does not apply to replacement OWTS where the connection fees and construction cost are greater than twice the total cost of the replacement OWTS and the local agency determines that the discharge from the OWTS will not affect groundwater or surface water to a degree that makes it unfit for drinking or other uses.

9.4.10 Except as provided for in sections 9.4.11 and 9.4.12, new or replacement OWTS with minimum horizontal setbacks less than any of the following:

9.4.10.1 150 feet from a public water well where the depth of the effluent dispersal system does not exceed 10 feet in depth.

9.4.10.2 200 feet from a public water well where the depth of the effluent dispersal system exceeds 10 feet in depth.

9.4.10.3 Where the effluent dispersal system is within 600 feet of a public water well and exceeds 20 feet in depth the horizontal setback required to achieve a two-year travel time for microbiological contaminants shall be evaluated. A qualified professional shall conduct this evaluation. However in no case shall the setback be less than 200 feet.

9.4.10.4 Where the effluent dispersal system is within 1,200 feet from a public water systems' surface water intake point, within the catchment of the drainage, and located such that it may impact water quality at the intake point such as upstream of the intake point for flowing water bodies, the dispersal system shall be no less than 400 feet from the high water mark of the reservoir, lake or flowing water body.

9.4.10.5 Where the effluent dispersal system is located more than 1,200 feet but less than 2,500 feet from a public water systems' surface water intake point, within the catchment area of the drainage, and located such that it may impact water quality at the intake point such as upstream of the intake point for flowing water bodies, the dispersal system shall be no less than 200 feet from the high water mark of the reservoir, lake or flowing water body.

9.4.11 For replacement OWTS that do not meet the above horizontal separation requirements, the replacement OWTS shall meet the horizontal separation to the greatest extent practicable. In such case, the replacement OWTS shall utilize supplemental treatment and other mitigation measures, unless the permitting authority finds that there is no indication that the previous system is adversely affecting the public water source, and there is limited potential that the replacement system could impact the water source based on topography, soil depth, soil texture, and groundwater separation.

9.4.12 For new OWTS, installed on parcels of record existing at the time of the effective date of this Policy, that cannot meet the above horizontal separation requirements, the OWTS shall meet the horizontal separation to the greatest extent practicable and shall utilize supplemental treatment for pathogens as specified in section 10.8 and any other mitigation measures prescribed by the permitting authority.

Tier 3 - Advanced Protection Management Program for Impaired Areas

Existing, new, and replacement OWTS that are near impaired water bodies may be addressed by a Total Maximum Daily Load (TMDL) and its implementation program, or special provisions contained in a LAMP.

A TMDL is a planning and management tool issued by the Regional Water Quality Control Board intended to identify, quantify, and control the sources of pollution within a given watershed such that water quality objectives are achieved and the beneficial uses of water are fully protected.

The term TMDL is used in two ways. First, it is the total maximum daily load of a pollutant that a water body can handle and still achieve acceptable water quality (this is also known as the loading capacity). Second, it is the document that includes all the supporting components.

Under Section 303(d) of the federal Clean Water Act, states are required to identify water bodies that do not meet water quality standards and are not supporting their beneficial uses. States must also identify the pollutant or stressor causing the impairments. The result of this effort is the 303(d) List of Impaired Waters. Placement on the 303(d) List of Impaired Waters generally triggers development of a TMDL for each waterbody and associated pollutant/stressor.

10.0 Advanced Protection Management Program

An APMP is the minimum required management program for all OWTS located near a water body that has been listed as impaired due to nitrogen or pathogen indicators pursuant to Section 303(d) of the Clean Water Act. Local agencies are authorized to implement APMPs in conjunction with an approved LAMP or, if there is no approved LAMP, Tier 1.

10.1 The geographic area for each impaired waterbody's APMP

Four Humboldt County waterbodies from the 303(d) List of Impaired Waters are listed as impaired for pathogens in Attachment 2 of the OWTS Policy. Those water bodies are: Clam Beach, Luffenholtz Beach, Moonstone County Park and Trinidad State Beach. Beginning May 13, 2013, and until adoption of a TMDL by the NCRWQCB, the APMP geographic area is defined in the OWTS Policy as “600 linear feet in the horizontal (map) direction of a water body listed in Attachment 2 of the OWTS Policy where the edge of that water body is the natural or levied bank for creeks and rivers, the high water mark for lakes and reservoirs, and the mean high tide line for tidally influenced water bodies, as appropriate.”

Alternatively, the OWTS Policy allows a local agency to place special provisions in a LAMP that will provide protection to the impaired water bodies as an alternative to applying the 600 foot boundary and/or the specific requirements of Tier 3 sections 10.8-10.16.

10.2 The requirements of an APMP will be in accordance with a TMDL Implementation Plan, if one has been adopted to address the impairment. An adopted TMDL implementation plan supersedes all other requirements in Tier 3.

10.3 In the absence of an adopted TMDL implementation plan, the requirements of an APMP will consist of any special provisions for the water body if any such provisions have been approved as part of a LAMP.

TMDL completion date for all of Humboldt County impaired waterbodies is 2020, as shown in Attachment 2 of the OWTS Policy. As TMDLs have not yet been established, Humboldt County will implement an APMP with special provisions, in lieu of continuing the specific requirements of Tier 3 sections **10.8 -10.16**.

Special Provisions

APMP line

The four listed impaired water bodies in Humboldt County are all adjacent to the Pacific Ocean. The geographic area of Humboldt County's proposed APMP is 200 linear feet in the horizontal (map) direction of each major drainage course upgradient of beach shorelines between Clam Beach and Trinidad State beach, to where timberlands begin (APMP line). (See Figures 1-5, following Table 1).

Special provisions within this APMP line are:

- 1. Public Education**
- 2. Research and evaluation of existing systems**
- 3. Water sample collection and analysis**
- 4. Criteria for new construction OWTS**
- 5. Criteria for repair and replacement OWTS**

Public Education

DEH staff will develop an educational program targeted at land owners in and around the APMP line to increase awareness of our LAMP, the APMP and its goal of improving surface water quality, and OWTS operation and maintenance.

Research and Evaluation of Existing Systems

Within each of the major drainages in this area, DEH staff will

- Identify, list, and map the parcels that intersect the APMP line
- From existing records, DEH will research and rank OWTS on each parcel according to perceived risk based on, but not limited to, the following: permit status, age, design and size of OWTS, record of repairs, distance to surface water, complaints, geography, parcel size, and parcel use;
- Use existing code authority requiring septic tank pumping every 7 years to gather information on systems at the time of septic tank pumping. DEH will attempt to be present at the time of pumping for as many OWTS as possible to interview system owner/operator and observe and evaluate OWTS condition. DEH staff will refine risk using these criteria, plus soil/site conditions, occupancy, and any other factors learned during the evaluation.

Water Sample Collection and Analysis

Concurrent with this research and evaluation, surface water sampling will be conducted by the DEH Beach Sampling program as well as Humboldt Baykeeper. Samples testing positive for pathogens will be further analyzed using bacterioides typing to identify whether the source of the bacteria is human, cow, bird or dog.

DEH Beach sampling locations are: Mill Creek at Trinidad State Beach; Little River at Moonstone Beach; Luffenholtz Creek at Luffenholtz Beach; Strawberry Creek at Clam Beach; and North Mad River Mouth.

Criteria for New Construction OWTS Within APMP

Until it is determined through laboratory testing that OWTS effluent is not likely the source of bacterial contamination of a 303(d) impaired water body, proposals for new construction on parcels that intersect an APMP line must meet all site evaluation, design, and construction standards. No variances will be considered. This is also true for OWTS modifications to accommodate proposed increased flow to an existing OWTS.

Criteria for Repairs to OWTS Within APMP

For repairs to existing systems and for replacement or modification of OWTS not related to increased effluent flow, compliance to the greatest extent practicable with all LAMP and RTM standards is required. Proposed variances will be considered on a case-by-case basis and may require supplemental treatment. Any variances requested will be reviewed with NCRWQCB staff prior to issuance.

The information gained from these special provisions will provide an evaluation of the conditions of as many of the OWTS as possible within the APMP area, and will provide analysis of surface water quality with respect to pathogen levels in an effort to identify the source of the pathogens.

DEH will collaborate with the NCRWQCB by sharing information pertaining to the impairments, provide advice on potential remedies, and regulate OWTS to the extent that our authority allows toward improvement of the impairments. All information gained will be shared with NCRWQCB for their use in TMDL development.

Table 1 – Variance Prohibition Areas

Section 9.1 Conditions/Characteristics	Geographic Area/Hydrologic Unit (HU) Tier 1 Requirements Infeasible	Mitigation Measures that may be Considered (Wet Weather Testing in All Areas)	
		New System (No Variance)	Repair
9.1.1 Degree of Vulnerability due to Hydrogeological conditions.	Westhaven, Fieldbrook, Fairhaven, Eureka Plain HU, Van Duzen River HU	NSOWTS, Supplemental Treatment	NSOWTS, Supplemental Treatment
9.1.2 High Quality Waters/Environmental Conditions requiring enhanced protection	Trinidad HU, Eureka Plain HU, Fairhaven, Van Duzen River HU	Supplemental Treatment	Supplemental Treatment
9.1.3 Shallow Soils	Westhaven, Fieldbrook, Eureka Plain HU	NSOWTS - Mound, Supplemental Treatment	NSOWTS - Mound, Supplemental Treatment
9.1.4 OWTS in area of high domestic well usage	Van Duzen River HU, Alton, Petrolia	Supplemental Treatment & Disinfection	Supplemental Treatment & Disinfection
9.1.5 OWTS in area of fractured rock	Benbow, Shelter Cove	NSOWTS, Supplemental Treatment	NSOWTS, Supplemental Treatment
9.1.6 OWTS in area of poorly drained soils	Fieldbrook, Eureka Plain HU, Petrolia	NSOWTS - Mound	NSOWTS - Mound, Supplemental Treatment
9.1.7 Surface Water vulnerable to pollution from OWTS	Trinidad HU, Eureka Plain HU, Fairhaven, Van Duzen River HU	NSOWTS, Supplemental Treatment	NSOWTS, Supplemental Treatment
9.1.8 OWTS within Tier 3 area	Trinidad HU, Clam Beach	NSOWTS, Supplemental Treatment, APMP Special Provisions	APMP Special Provisions
9.1.9 Area of high OWTS density	Pacific Manor subdivision, Fairhaven, Van Duzen River HU	NSOWTS, Supplemental Treatment, Cumulative Impact Study, Water Efficient Fixtures	
9.1.10 Parcel size susceptible to hydraulic mounding, nitrogen loading	Fairhaven, Pacific Manor subdivision, Petrolia, Hydesville,	NSOWTS, Supplemental Treatment	NSOWTS, Supplemental Treatment
9.1.11 Multiple OWTS predating standards	Alton, Petrolia, Fairhaven, Westhaven		Conformance with RTM
9.1.12 OWTS located within pertinent setbacks	Alton	NSOWTS, Supplemental Treatment & Disinfection	NSOWTS, Supplemental Treatment & Disinfection

Trinidad HU covers the area from Big Lagoon south to Little River.

Eureka Plain HU includes Jacoby Creek, Bayside, Freshwater, Elk River.

Van Duzen River HU covers the area from Bridgeville west to Hydesville.

The table above lists the primary areas in Humboldt County where conditions listed in 9.1.1 – 9.1.12 occur and prevent the use of Tier 1 siting criteria for the design and installation of an OWTS.

FIGURE 1

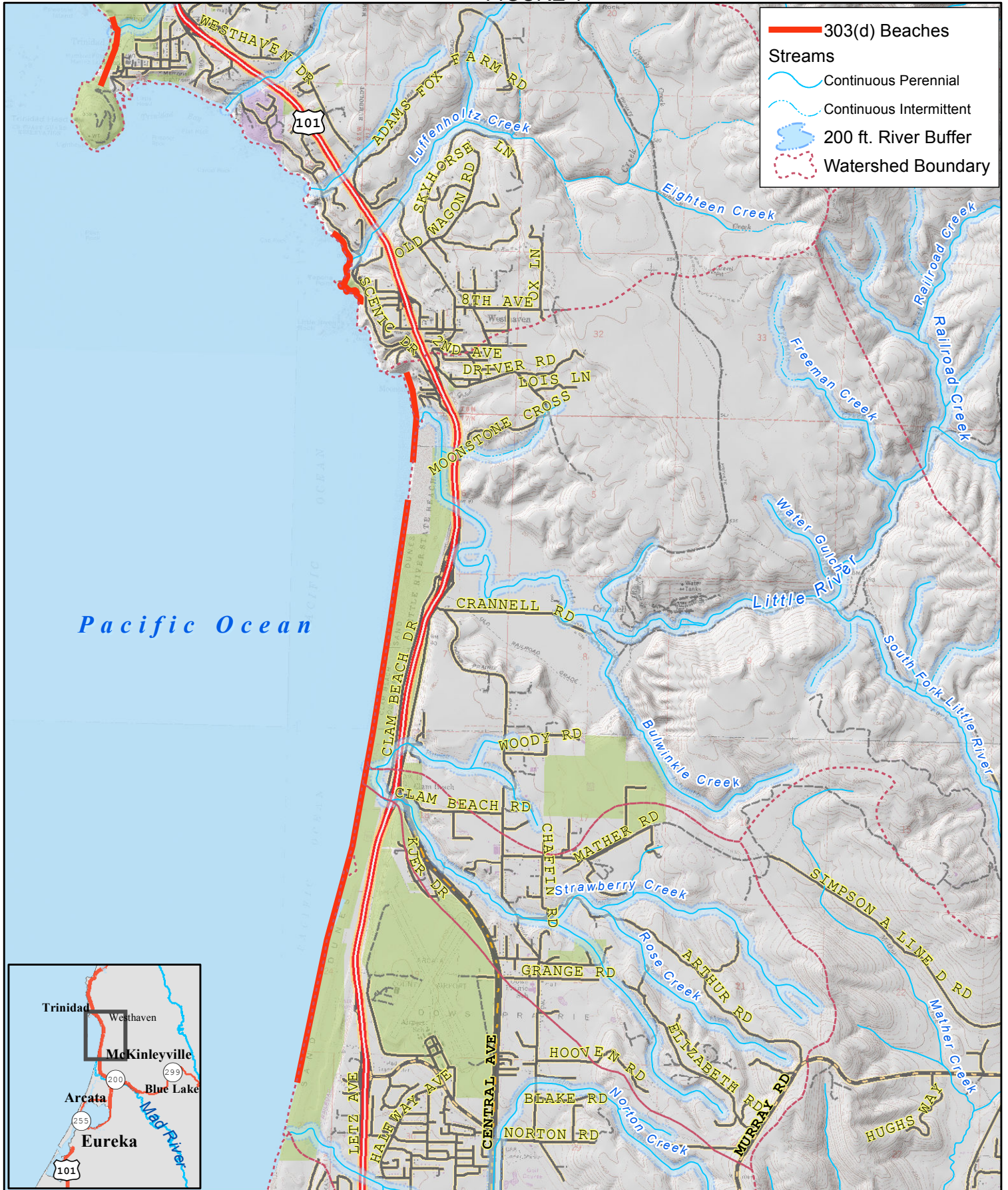

Draft Advanced Protection Management Plan/303(d) Listed Beaches 3/7/16
OWTS Policy 303(d) Listed Beaches Study Area



This map is intended for display purposes only and should not be used for precise measurement or navigation. Map compiled by Humboldt County Planning and Building Department, Mar. 2016, contact: jvondohlen@co.humboldt.ca.us ArcGIS 10.3.1 file H:\arps\303d_beaches_StudyArea.mxd

FIGURE 2

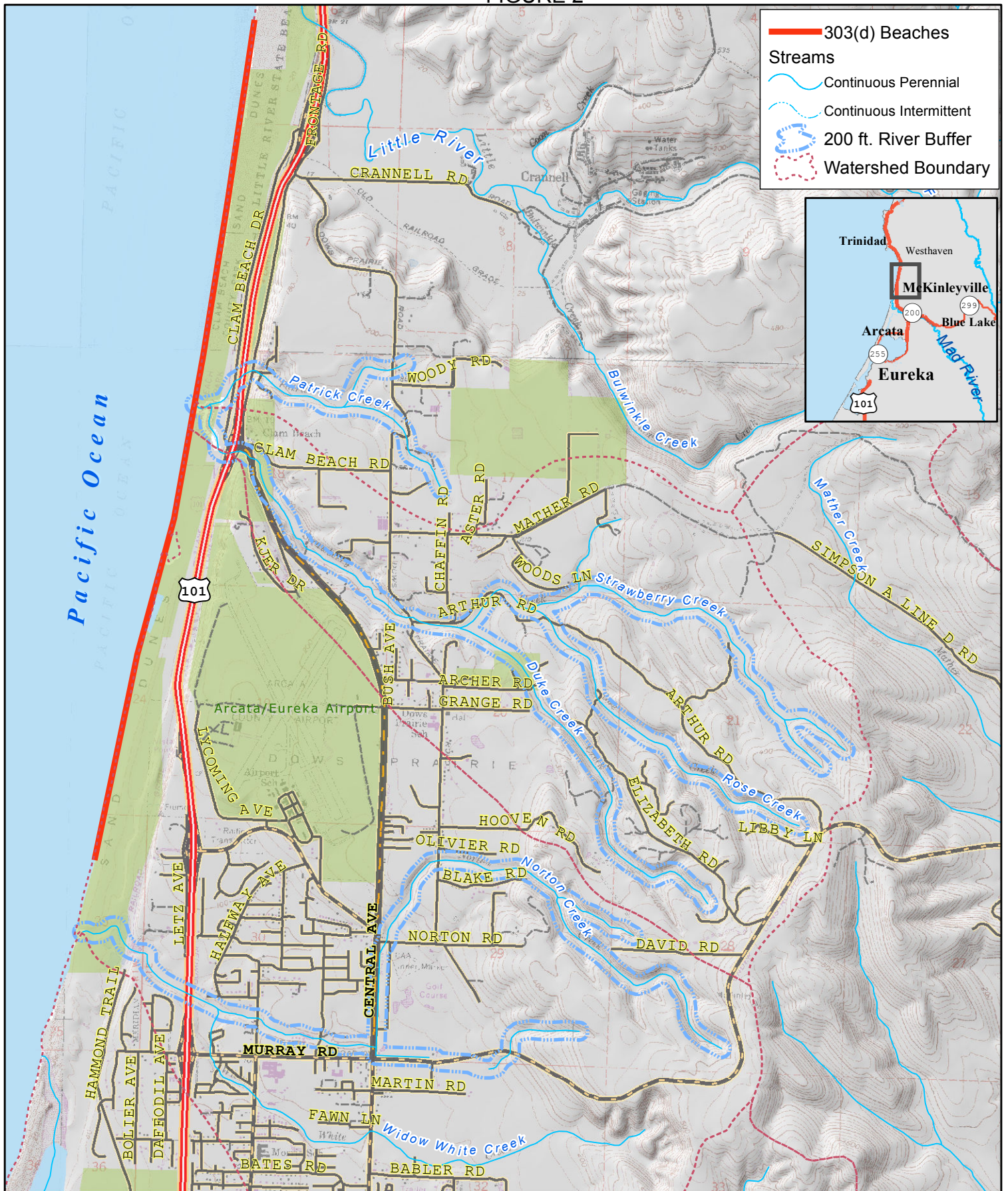

303(d) Beaches
Streams
 Continuous Perennial
 Continuous Intermittent
 200 ft. River Buffer
 Watershed Boundary



Draft Advanced Protection Buffer Zones/303(d) Listed Beaches 3/7/16
 Clam Beach

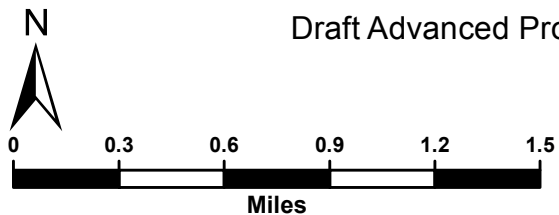

This map is intended for display purposes only and should not be used for precise measurement or navigation. Map compiled by Humboldt County Planning and Building Department, Mar. 2016, contact: jvondohlen@co.humboldt.ca.us ArcGIS 10.3.1 file H:\arps\303d_beaches_Clam.mxd

FIGURE 3

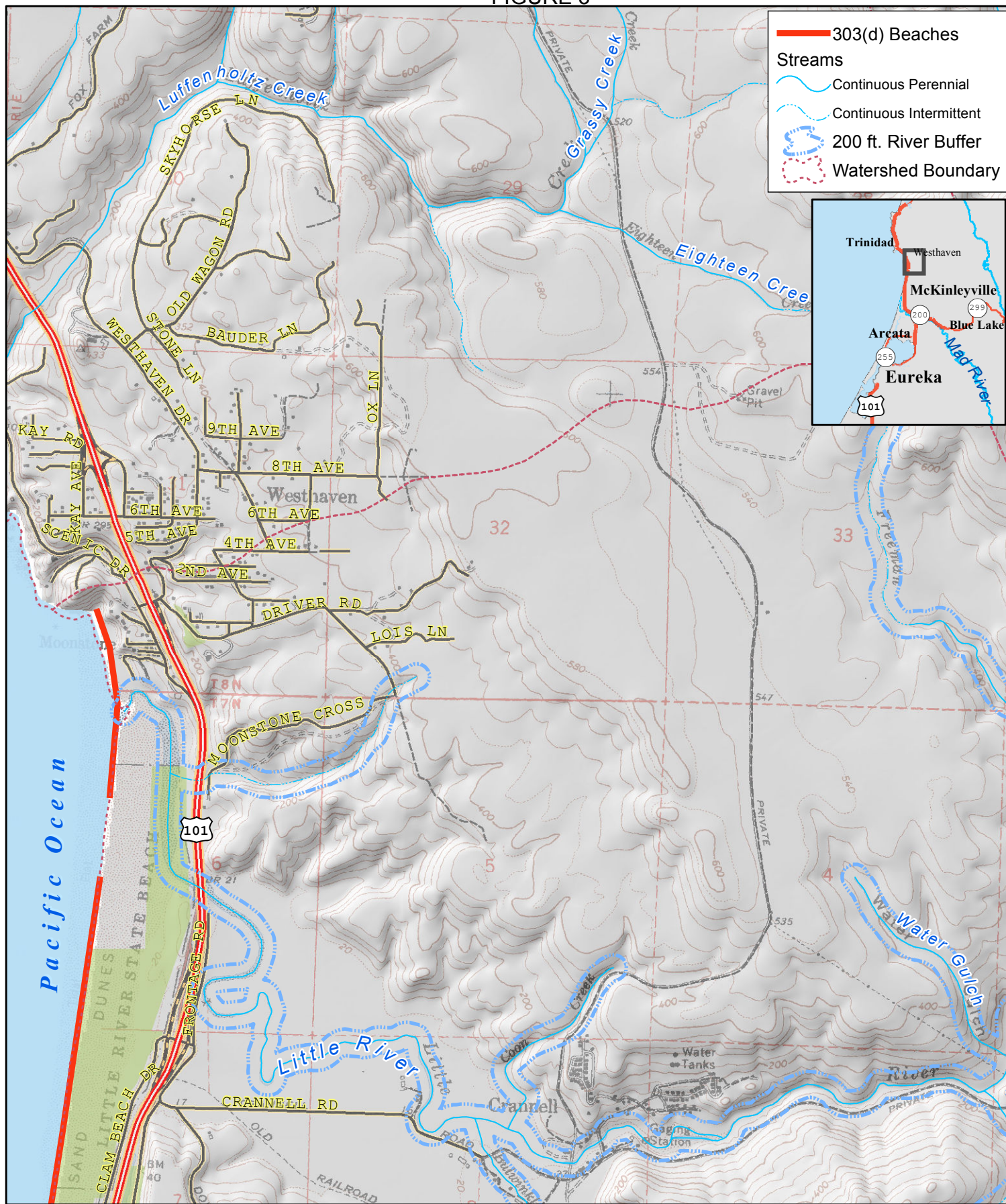

Draft Advanced Protection Buffer Zones/303(d) Listed Beaches 3/7/16
Moonstone State Beach

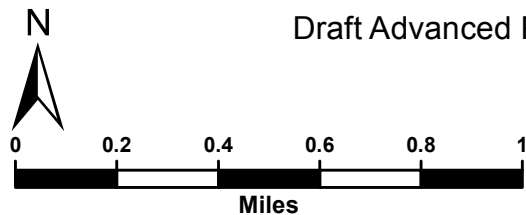

This map is intended for display purposes only and should not be used for precise measurement or navigation. Map compiled by Humboldt County Planning and Building Department. Mar. 2016, contact: jvondohlen@co.humboldt.ca.us ArcGIS 10.3.1 file H:\arps\303d_beaches_Moonstone.mxd

FIGURE 4

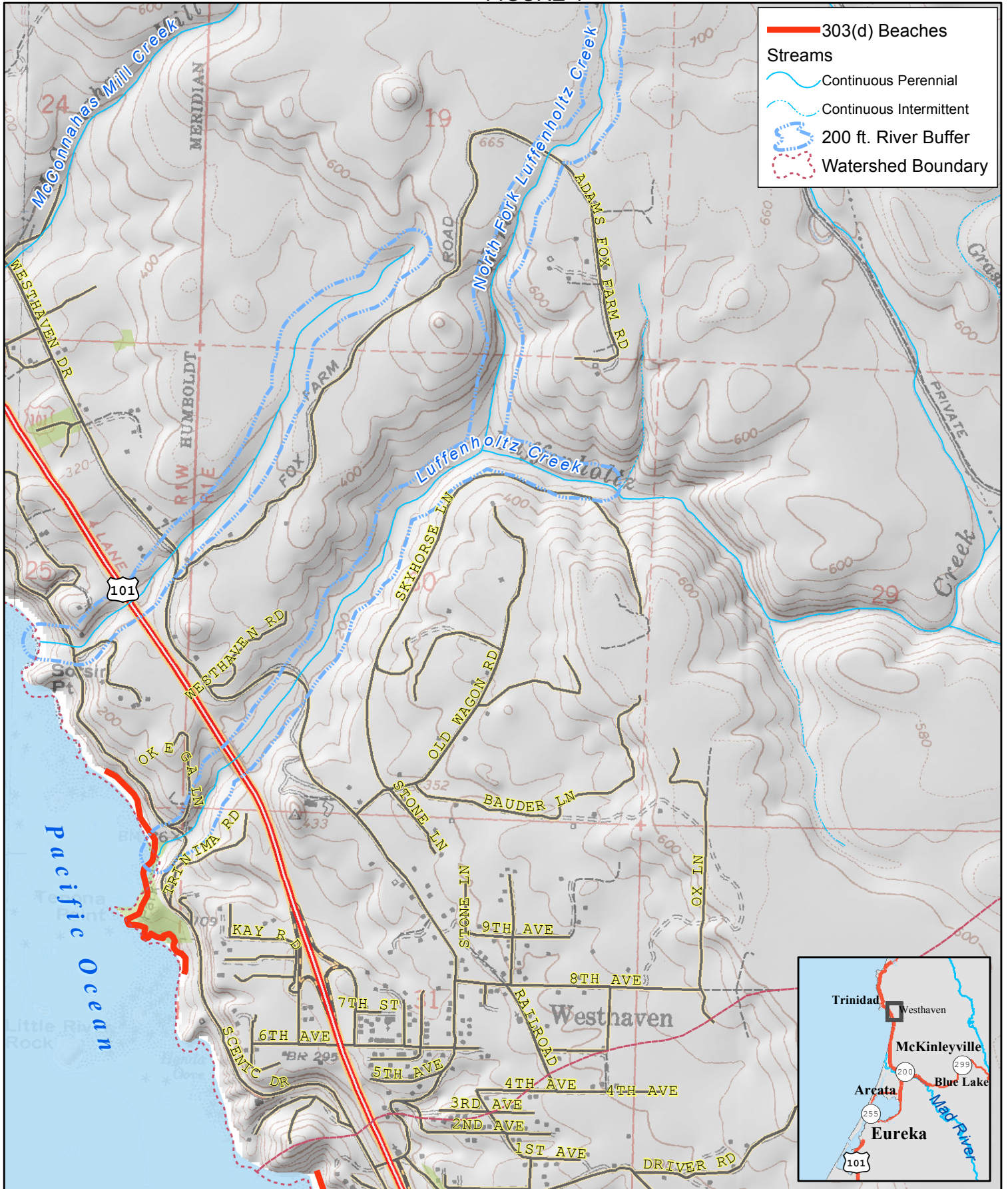

Draft Advanced Protection Buffer Zones/303(d) Listed Beaches 3/7/16
Luffenholtz Beach

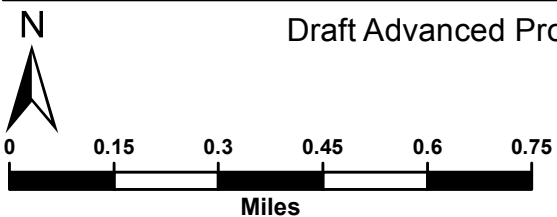

This map is intended for display purposes only and should not be used for precise measurement or navigation. Map compiled by Humboldt County Planning and Building Department, Mar. 2016, contact: jvondohlen@co.humboldt.ca.us ArcGIS 10.3.1 file H:\arps\303d_beaches_Luffenholtz.mxd

FIGURE 5

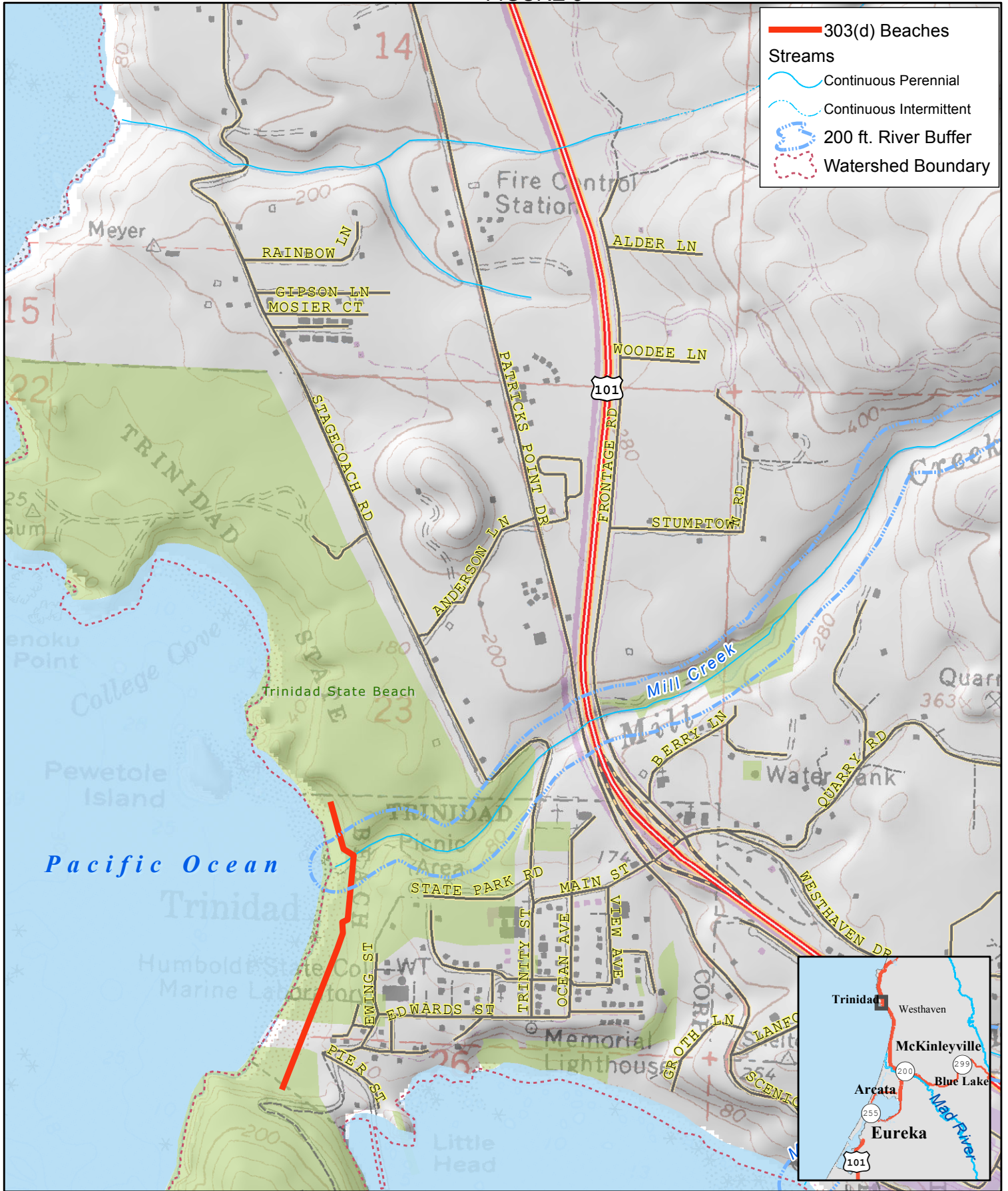

Draft Advanced Protection Buffer Zones/303(d) Listed Beaches 3/7/16
Trinidad State Beach

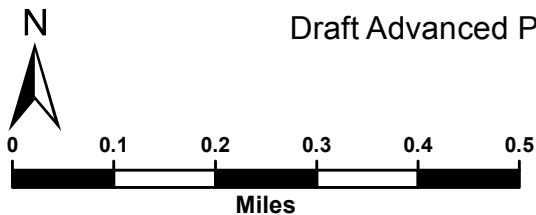

This map is intended for display purposes only and should not be used for precise measurement or navigation. Map compiled by Humboldt County Planning and Building Department, March 2016, contact: jvondohlen@co.humboldt.ca.us ArcGIS 10.3.1 file H:\arps\303d_beaches_TrinidadStateBeach.mxd

Tier 4 – OWTS Requiring Corrective Action

OWTS that require corrective action or are either presently failing or fail at any time while this Policy is in effect are automatically included in Tier 4 and must follow the requirements as specified. OWTS included in Tier 4 must continue to meet applicable requirements of Tier 0, 1, 2 or 3 pending completion of corrective action.

11.0 Corrective Action for OWTS

11.1 Any OWTS that has pooling effluent, discharges wastewater to the surface, or has wastewater backed up into plumbing fixtures, because its dispersal system is no longer adequately percolating the wastewater is deemed to be failing, no longer meeting its primary purpose to protect public health, and requires major repair, and as such the dispersal system must be replaced, repaired, or modified so as to return to proper function and comply with Tier 1, 2, or 3 as appropriate.

11.2 Any OWTS septic tank failure, such as a baffle failure or tank structural integrity failure such that either wastewater is exfiltrating or groundwater is infiltrating is deemed to be failing, no longer meeting its primary purpose to protect public health, and requires major repair, and as such shall require the septic tank to be brought into compliance with the requirements of Section 8 in Tier 1 or a Local Agency Management Program per Tier 2.

11.3 Any OWTS that has a failure of one of its components other than those covered by 11.1 and 11.2 above, such as a distribution box or broken piping connection, shall have that component repaired so as to return the OWTS to a proper functioning condition and return to Tier 0, 1, 2, or 3.

11.4 Any OWTS that has affected, or will affect groundwater or surface water to a degree that makes it unfit for drinking or other uses, or is causing a human health or other public nuisance condition shall be modified or upgraded so as to abate its impact.

11.5 If the owner of the OWTS is not able to comply with corrective action requirements of this section, the Regional Water Board may authorize repairs that are in substantial conformance, to the greatest extent practicable, with Tiers 1 or 3, or may require the owner of the OWTS to submit a report of waste discharge for evaluation on a case-by-case basis. Regional Water Board response to such reports of waste discharge may include, but is not limited to, enrollment in general waste discharge requirements, issuance of individual waste discharge requirements, or issuance of waiver of waste discharge requirements. A local agency may authorize repairs that are in substantial conformance, to the greatest extent practicable, with Tier 2 in accordance with section 9.2.3 if there is an approved Local Agency Management Program, or with an existing program if a Local Agency Management Program has not been approved and it is less than 5 years from the effective date of the Policy.

11.6 Owners of OWTS will address any corrective action requirement of Tier 4 as soon as is reasonably possible, and must comply with the time schedule of any corrective action notice received from a local agency or Regional Water Board, to retain coverage under this Policy.

11.7 Failure to meet the requirements of Tier 4 constitutes a failure to meet the conditions of the waiver of waste discharge requirements contained in this Policy, and is subject to further enforcement action.

DEH maintains an electronic database for tracking receipt and response to public complaints. Our complaint investigation policy sets a response goal of five days to complaints received. Complaints alleging conditions such as failing OWTS or sewage spills require immediate attention and a rapid response time is employed.

HCC section 611-2(i) defines OWTS failure; section 612-2 requires that a permit be obtained to make a repair to a failed system; and section 612-4 provides investigation and abatement authority.

Page 23 of the RTM provides information on obtaining permits for repairs.

If, through the assessment and reporting requirements of the OWTS Policy or through any other means, DEH finds that its standards are not adequate to protect water quality and public health, additional protective measures will be considered and proposed.

Appendix 1: Humboldt County Onsite Wastewater Regulations and Technical Manual



Environmental Health
 Melissa Martel, Director
 100 H Street, Eureka, CA 95501
 phone: (707) 445-6215 | fax: (707) 441-5699

Humboldt County Onsite Wastewater Treatment System (OWTS) Regulations and Technical Manual

ISSUED AND EFFECTIVE _____

FILED WITH THE CLERK OF HUMBOLDT COUNTY

 Kelly Sanders
 Clerk Recorder

DATED: _____

ISSUED BY THE HUMBOLDT COUNTY HEALTH OFFICER

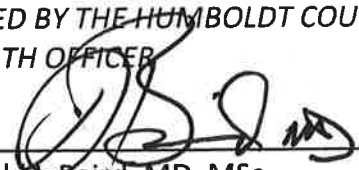

 Donald I. Baird, MD, MSc
 Public Health Officer, Humboldt County

DATED: _____



Table of Contents

INTRODUCTION	1
ELIGIBILITY	1
PROHIBITIONS	2
VARIANCE PROHIBITION AREAS	2
PART 1 -SITE EVALUATION	4
1.1 SOIL PROFILES.....	4
1.2 SOIL TESTING.....	5
1.3 DEPTH TO GROUNDWATER DETERMINATIONS	6
1.4 REPORTING OF DATA.....	8
1.5 DEH RESPONSIBILITIES FOR MONITORING WELL NOTIFICATIONS.....	8
PART 2 -DESIGN	9
2.1 WASTEWATER FLOW RATES	9
2.2 SEPTIC TANK SIZING	9
2.3 STANDARD (GRAVITY) OWTS	9
2.4 NON-STANDARD OWTS.....	13
2.5 INTERCEPT DRAINS (CURTAIN DRAIN)	20
2.6 DESIGN SUBMITTAL	20
PART 3 -PERMITTING	22
3.1 NEW CONSTRUCTION	22
3.2 REPAIR PERMIT	23
3.3 MODIFICATION PERMIT	23
3.4 OWTS INSTALLED WITHOUT PERMIT	24
3.5 STRUCTURE REMODEL, REPLACEMENT OR CHANGE IN USE.....	25
3.6 SEPTIC TANK DESTRUCTION/ABANDONMENT.....	26
3.7 GREASE INTERCEPTORS.....	26
3.8 ADDITIONAL CONSIDERATIONS	27
PART 4 -CONSTRUCTION AND INSTALLATION.....	29
4.1 GENERAL INSTALLATION REQUIREMENTS.....	29
4.2 BUILDING SEWER REQUIREMENTS	29
4.3 SEPTIC TANK REQUIREMENTS	30
4.4 GREASE INTERCEPTORS.....	31
4.5 PUMP TANK / PUMP / CONTROL REQUIREMENTS	31
4.6 DISTRIBUTION BOXES	33
4.7 GRAVITY OWTS.....	33
4.8 OWTS CONSTRUCTION INSPECTION	34
4.9 OWTS OPERATION AND MAINTENANCE	35

List of Appendices

- Appendix A – Soil Textural Triangle/Percolation Suitability Chart
- Appendix B – Observation Well Reporting Form
- Appendix C – Quantities of Expected Daily Wastewater Flow
- Appendix D – Standard Details
- Appendix E – OWTS Setback Requirements
- Appendix F – Policy for the Use of Existing Onsite Wastewater Treatment Systems (OWTS)
- Appendix G – Graywater Regulations
- Appendix H – Variance Prohibition Areas

Table of Figures

FIGURE 1 – GRAVEL DISPERSAL TRENCH SECTION	11
FIGURE 2 – MINIMUM DEPTH TO GROUNDWATER	13
FIGURE 3 – TYPICAL PRESSURE DISTRIBUTION SYSTEM	15
FIGURE 4 – PRESSURE DISTRIBUTION TRENCH SECTION	16
FIGURE 5 – TYPICAL MOUND SYSTEM.....	17
FIGURE 6 – TYPICAL AT-GRADE SYSTEM	18

List of Acronyms

APMP	Advanced Protection Management Program
BOS	Humboldt County Board of Supervisors
DEH	Humboldt County Division of Environmental Health
HCC	Humboldt County Code
IAPMO	International Association of Plumbing and Mechanical Officials
LAMP	Local Agency Management Program
NCRWQCB	North Coast Regional Water Quality Control Board
NSF	National Sanitation Foundation
NSOWTS	Non-Standard Onsite Wastewater Treatment System
OWTS	Onsite Wastewater Treatment System
OWTS Policy	Water Quality Control Plan for Siting, Design, Operation, and Maintenance of Onsite Wastewater Treatment Systems
RTM	Humboldt County Onsite Wastewater Regulations and Technical Manual
VPA	Variance Prohibition Area

Introduction

California Water Code section 13140 directs the State Water Resources Control Board (State Water Board) to formulate and adopt state policy for water quality control. Water Code sections 13290-13291.7 requires the State Water Board to adopt and implement regulations or standards for the permitting and operation of onsite wastewater treatment systems (OWTS).

On June 19, 2012, the State Water Board adopted the *Water Quality Control Policy for Siting, Design, Operation, and Maintenance of Onsite Wastewater Treatment Systems* (OWTS Policy). The policy took effect on May 13, 2013.

Humboldt County Code (HCC) Title VI Division 1 Water and Sewage provides the local authority for management of OWTS. HCC 611-1 presents the Board of Supervisors findings that the dispersal field (leach field) method of sewage treatment is the most appropriate for rural lands and is to be considered a permanent means. HCC 612-1 directs the Health Officer to issue regulations to carry out the provisions of Division 1.

Humboldt County *Onsite Wastewater Treatment System Regulations and Technical Manual* (RTM) replaces *Humboldt County Sewage Disposal Regulations* and is prepared and adopted in accordance with HCC 612-1. Terms used throughout the RTM are defined in HCC 611-2 and in the OWTS Policy. Where a definition differs, the definition in HCC applies.

The Humboldt County Department of Health and Human Services, Division of Environmental Health (DEH) is the authorized representative of the Health Officer in matters pertaining to onsite wastewater treatment system (OWTS) management in Humboldt County.

Eligibility

A site that is greater than 300 feet from a public sewer can be evaluated for OWTS use. Suitable soil conditions and land form features are necessary for an OWTS to perform in a manner which protects public health and the environment. In some cases, parcels lacking public sewer service may not support the use of an OWTS due to poor soil conditions and/or other unsuitable features as determined by the Health Officer.

A particular building situation may not be allowed to utilize an OWTS because of:

1. Lack of suitable soil depth; or impervious or saturated soil conditions.
2. Steep slopes (greater than thirty percent slope).
3. History of failures in area.
4. Other factors that may be identified by the Health Officer.

HCC 614-1 authorizes the Board of Supervisors to declare a moratorium on the issuance of OWTS permits in areas of existing or potential community contamination problems. There are no areas in Humboldt County subject to such moratorium at the date of this document.

Prohibitions

The following practices and conditions are prohibited in Humboldt County:

1. Cesspools of any kind or size.
2. Holding tanks as a permanent means of sewage management except as specified in HCC 613-4.
3. OWTS receiving a projected flow over 10,000 gallons per day unless permitted through the Regional Water Quality Control Board (RWQCB).
4. OWTS that utilize any form of effluent dispersal that discharges on or above the post installation ground surface such as sprinklers, exposed drip lines, free-surface wetlands, or a pond.
5. OWTS installed slopes greater than 30 percent without a slope stability report approved by a registered professional.
6. Decreased leaching area for IAPMO certified dispersal systems.
7. New OWTS installation without 100% reserve area for a replacement system.
8. OWTS utilizing supplemental treatment without periodic monitoring or inspections.
9. Less than two (2) feet of separation between the bottom of dispersal system to seasonal groundwater.

Variance Prohibition Areas

Variance Prohibition Areas (VPA) respond to the OWTS Policy's Tier 2 and Tier 3 requirement to provide special consideration to protect public health and water quality in areas which exhibit challenging conditions including high groundwater elevations, extremely coarse or restrictive soils, and high OWTS or water well density. VPAs are generalized areas of Humboldt County where one or more challenging conditions are known to exist (see Appendix H of this document).

Additionally, surface water bodies listed in Attachment 2 of the OWTS Policy are included as VPAs. They are further addressed through an Advance Protection Management Program (APMP) described in Tier 3 of the Humboldt County Local Agency Management Program (LAMP). An APMP, required by the State OWTS Policy, implements protective measures near impaired surface water bodies listed by the State. Other than APMP areas, VPAs are not specifically delineated or mapped.

New OWTS design proposals within VPAs must strictly adhere to these regulations. Variances (formerly known as waivers) cannot be granted for new OWTS construction. DEH must be on site for all site evaluations performed in the VPAs. The Variance Prohibition Areas are:

- The Eureka Plain Hydrologic Unit (includes the Jacoby Creek, Freshwater, and Elk River watersheds);
- Westhaven and Fieldbrook;
- The Pacific Manor subdivision in Arcata;
- The Trinidad Hydrologic Unit (covering the areas from Big Lagoon south the Little River);
- Fairhaven;
- Van Duzen River Hydrologic Unit (cover the area from Bridgeville to and including Hydesville);
- Alton;
- Petrolia;
- Benbow and Shelter Cove;
- All parcels located less than 200' from surface water drainage courses upgradient of beach shorelines between Clam Beach and Trinidad State Beach (e.g. Little River, Strawberry Creek, Mill Creek, and Luffenholtz Creek watersheds).

PART 1 - Site Evaluation

Site evaluations are required for all OWTS proposals to ensure proper OWTS design and compliance with site suitability criteria. **Site evaluations conducted in the variance prohibition areas must be observed by a DEH inspector.** A DEH inspection/site evaluation report will corroborate observations and outline testing required for development in the variance prohibition areas.

Site evaluations shall be conducted by a Qualified Professional as defined in HCC 611.2(m): Qualified Professional means a Registered Civil Engineer, Environmental Health Specialist, Professional Geologist, or Certified Soil Scientist who has experience designing standard or non-standard wastewater treatment systems. Site evaluations shall be conducted in accordance with the following standards.

General site features to be determined include:

- Land area available for primary and replacement dispersal area.
- Ground slope and soil characteristics (limiting layers in soil profiles and anticipated ground water levels) in and around the dispersal field area.
- Location of cut banks, fills, or evidence of past grading activities, natural bluffs, soil landscape formations and unstable land forms within 50 feet of the dispersal field and replacement area.
- Location of wells, intercept drains, streams and other bodies of water on the property and within 100 feet on adjacent properties.
- Identification of critical setbacks to observed features

1.1 Soil Profiles

Soil characteristics shall be evaluated by observing soil profiles. A minimum of one (1) backhoe excavation in the primary dispersal field and one (1) in the replacement area are required. Additional profile observations may be required to establish suitable dispersal field areas.

In cases where backhoe access is not feasible, augured test holes may be an acceptable alternative if prior approval is obtained from DEH. When this method is employed, three test holes in the primary dispersal field and three in the replacement field are required.

In the evaluation of new subdivisions, no less than two (2) soil excavations shall be made to identify a suitable primary and replacement dispersal field for each proposed parcel.

A sketch showing a typical backhoe test pit is presented in Standard Details, Appendix D.1. The following details shall be observed and reported from the ground surface to a limiting condition or to five feet below the proposed disposal field trench bottom:

1. Thickness of soil layers, and coloring (using Munsell Color Identification method) soil structure and texture description using the USDA classification method.
2. Plasticity Index (only necessary if requesting authorization for dry-weather perc testing of Zone 3 or Zone 4 soils).
3. Depth to a limiting condition such as hardpan, rock strata, fractured rock or impermeable soil layer.
4. Depth to observed groundwater.
5. Depth to and description of soil mottling and gleying.
6. Other prominent soil features which may affect site suitability, such as structure, stoniness, consistence, root zones and pores, dampness etc.

1.2 Soil Testing

Soil testing to demonstrate suitable dispersal field conditions shall be based on the most restrictive soil horizon encountered within three (3) feet of the anticipated dispersal trench bottom. This applies to both **textural analysis** and **percolation testing**.

Soil samples representing the most restrictive horizons within the excavated soil profile shall be collected by the Qualified Professional and analyzed for texture and bulk density at a professional laboratory. The results shall be plotted on the Soil Percolation Suitability Chart (soil textural triangle) presented in Appendix A.

Soils within Zone 1 have minimal filtration capabilities, requiring increased separation to seasonal high groundwater. See Figure 2.

Soils within Zone 2 are suitable and may not require further testing if adequate separation to groundwater exists. See Table 2 for prescriptive leachfield sizing parameters. Alternative sizing can be approved with acceptable perc results.

Percolation testing of soils falling within Zone 1 and Zone 2 may occur outside of wet weather conditions provided the test holes are adequately presoaked as described in the Percolation Test Procedures which follow.

Soils within Zone 3 and Zone 4 require percolation testing; such testing shall be conducted during wet weather conditions. DEH may authorize dry weather perc testing with pre-soak if the plasticity index of the most restrictive soil layer is less than 20 (ASTM D 4318-84).

1.2.1 Percolation Test Preparation

The following procedures are required for determining a stabilized percolation rate.

- a. Digging a Test Hole – After identifying the most restrictive soil type within three (3) feet of the anticipated trench bottom, dig a hole 12 inches square or bore a hole 13-14 inches in diameter into that soil. Depth of the hole must be a minimum of 12 inches.
- b. Preparation of a Test Hole – Remove any smeared soil surfaces from the sides of the hole to provide as natural a soil interface as practical to infiltrating water. Remove loose material from the bottom of the hole and add an inch or two of coarse sand or fine gravel to protect the bottom from scouring. Make sure there are no rodent burrows, cracks or root holes which may cause erroneous results.
- c. Presoaking a Test Hole – Presoaking is not required during the wet weather test period. Where a soils textural analysis indicates that a particular sample falls within the “Coarse” Zone 1 or “Acceptable” Zone 2 range of the Soil Percolation Suitability chart or DEH has authorized dry-weather testing of Zone 3 or Zone 4 soils, testing may be conducted outside of wet weather conditions provided the test hole is presoaked continuously for 12 hours or with a minimum of four complete re-fillings beginning the day prior to conducting the percolation test. Start the test 24 hours after water is first added to the test hole.
- d. Saturating the Test Hole – During the dry and wet weather testing periods, saturate the soil by filling the test hole with water to at least 12 inches above the bottom of the hole, refilling as needed to keep the full depth of the hole saturated for a one hour period. One hour after water is first added to the hole, start the test.
- e. Begin the test with 12 inches of water above the bottom of the hole. Record the drop in water level at time intervals appropriate for the observed rate of infiltration. Refill the hole to 12 inches as needed until a stabilized rate is measured for a minimum of three consecutive time intervals. Document the percolation test procedure and results on the DEH Percolation Testing Form, or equivalent.

1.3 Depth to Groundwater Determinations

The anticipated highest level of groundwater shall be reported as the highest extent of soil mottling observed within the soil profile or by direct observation of groundwater levels during wet weather conditions.

1.3.1 Soil Mottling

In most cases, ground water levels and seasonally saturated soils can be predicted (summer or winter) by the highest extent of soil mottling or gleying observed in the soil profile. The most conservative approach to dispersal field design is based on the assumption that mottling levels reflect seasonal saturation.

On older North Coast landforms, mottling may be a remnant of prior geologic/climatic conditions, and may not reflect seasonal saturation. Likewise, some sites underlain by very coarse soils or gravel may not exhibit mottling even though saturation occurs every winter. For these sites, the highest extent of saturation must be determined by the **direct observation** method. Site evaluators shall use the direct observation method whenever uncertainties about groundwater levels occur.

Information about areas where transient water tables occur may be obtained from DEH Land Use staff.

1.3.2 Wet Weather Criteria

The **wet weather test period** in Humboldt County begins after the cumulative rainfall in Eureka exceeds 19 inches or 10 inches of rain occurs within a thirty day period. The test period may be opened earlier if DEH determines that saturated conditions exist. Alternatively, the test period may be delayed if DEH determines, based on its own observations and the input of Qualified Professionals, that saturated conditions do not yet exist. The test period may be suspended if insufficient rain occurs shortly after the test period is opened. The season will be closed **April 1st** unless extended in writing by the Director of DEH.

Wet season percolation testing is required for sites where clay (zone 3 or 4) soils exist and within the Variance Prohibition Area(s). For sites outside the Variance Prohibition Area(s), soil testing results confirming a low shrink swell potential (Plasticity Index of less than 20, ASTM D 4318-84) may remove the wet weather requirement. Testing must be completed in the most restrictive layers within effluent absorption or treatment portions of the proposed dispersal system including the trench side wall and/or soils within 3 feet of proposed trench Percolation testing of more than one horizon may be necessary to determine which of the layers is most restrictive.

1.3.3 Direct Observation Method

Since groundwater levels may fluctuate throughout the wet season, it is necessary to monitor the levels over an extended period of time. The monitoring is accomplished by the installation of monitoring wells (at least one in the proposed dispersal field and one in the proposed reserve area. Measurements must be taken at least once each week for at least three (3) consecutive business weeks during the wet weather testing period. For accurate determinations of the highest extent of groundwater, the duration of monitoring should include at least one substantial rainfall event totaling more than 0.5" of rain in a 24 hour period. Direct observation is required for sites within the Variance Prohibition Area(s).

1.3.4 Monitoring Well Construction

The construction of monitoring wells must conform as closely as possible to Appendix D.2, Typical Observation Well Construction detail.. The wells must be augured, drilled,

or bored. The placement of pipes in backhoe pits may be acceptable if supervised by a Qualified Professional. The depth of wells must be sufficient to verify appropriate groundwater separation from the bottom of proposed dispersal trenches. Wells of shallow depth maybe required to identify perched seasonal water/saturation in upper soil horizons. Certain sites may require more than two (2) wells. Sufficient well depth and spacing between wells must be provided to obtain valid results.

The “Notification of Wet Weather Monitoring Well Installation” form and the appropriate fee shall be submitted to DEH within (5) days of monitoring well construction. Uniquely identified, well locations, assessor’s parcel number, cross-section diagram of as-built wells, and soils profile must be included. Applicants are encouraged to install observation wells as early in the season as possible to ensure completion of monitoring requirements prior to the typical April 1st deadline. The notification form is available at DEH or <http://www.humboldt.gov/730/Land-Use-Program>

1.4 Reporting of Data

Monitoring well measurements must be recorded in tabular form. Every measurement taken shall be included. Appendix B provides a typical observation well reporting form to record data collected during the wet weather period. This data must be submitted with the proposed OWTS design and permit application.

1.5 DEH responsibilities for monitoring well notifications

DEH will verify that all required information is complete and accurate and will make a minimum of one site visit to measure and record water levels in each monitoring well reported.

PART 2 - Design

The completed site evaluation will address each of the following site criteria and establish appropriate OWTS design parameters intended to protect water quality and prevent health hazards and nuisance conditions arising from the improper discharge of wastewater. All OWTS shall be designed, constructed and operated in a manner which ensures discharged effluent does not surface at any time and does not adversely impact groundwater.

2.1 Wastewater Flow Rates

Estimates of wastewater flows for the design of conventional **domestic** OWTS shall be based on 150 gallons per day per bedroom up to three (3) bedrooms; additional bedrooms will be considered to generate 75 gallons per day (gpd). Residential OWTS shall be sized for a minimum flow of 300 gallons per day projected flow.

Estimated flow rates for systems receiving wastewater **flows greater than 1500 gallons per day and/or from commercial** establishments shall take into account peak loading rates and the chemical characteristics of the wastewater. Estimates of wastewater flow expected from various types of establishments are listed in Appendix C.

2.2 Septic Tank Sizing

Septic Tanks shall be sized in accordance with Table 1 – Septic Tank Sizing Requirements, below. Septic tanks shall be constructed and installed as specified in Part 4, Section 4.3.

Table 1 - Septic Tank Sizing Requirements

Required Tank Volume	Intended Use
750 gallons	1 Bedroom Cabin/Mobile Home
1200 gallons	2 Bedroom Residence
1500 gallons	3-4 Bedroom Residence
Three Times Daily Flow	Other Applications (E.g. commercial, multi-family, etc.)

2.3 Standard (Gravity) OWTS

2.3.1 Application Rates

The design of a conventional **gravity-flow dispersal system** (leachfield) shall be based on the estimated daily flow set forth in the section 2.1 and soil application rates derived from either stabilized percolation rates and/or soil texture as listed in the Table 2. Sites where sufficient depths of Zone 2 soils occur may not require percolation testing to complete a dispersal system design. The application rates associated with the soil texture as shown in the table below can be used to calculate dispersal system size.

Table 2 - Soil Application Rates

Percolation Rate(mpi)	Soil Application Rate gpd/ft²	Zone 2 Soil Texture (for use when no percolation testing conducted)
5	0.732	
10	0.554	
15	0.481	Loamy Sand
20	0.425	
25	0.389	Sandy Loam
30	0.363	
35	0.344	Sandy Clay Loam
40	0.323	
45	0.305	Silt Loam
50	0.296	
55	0.285	
60	0.277	

As described in Part 1 – Site Evaluation, soil application rates for sizing OWTS dispersal field trenches shall be based on percolation testing and/or textural analysis of the most restrictive soil group encountered in the 36 inch soil column beneath the trench bottom.

Soils having percolation rates faster than 5 minutes per inch or slower than 60 minutes per inch may not be suitable for the installation of a standard (gravity-flow) dispersal system and require consideration of a Non-Standard (pressurized) dispersal system.

2.3.2 Dispersal Field Sizing – Graveled Trench

To calculate the required length of trench for a typical gravel and perforated pipe, gravity-flow dispersal field:

- a. Divide the projected **daily flow** by the appropriate **soil application rate** – this yields the **total square footage of absorption area** required in the dispersal field.

Example: **Daily flow** = 450gpd / **Application rate** = 0.5gpd/ft²
 $450/0.5\text{ft}^2 = 900\text{ft}^2$

- b. The **total lineal feet of dispersal field trench** needed is determined by dividing the **total square footage of absorption area** required (900ft² from above) by the **useable square footage of trench sidewall per lineal foot of trench** (as measured beneath the perforated pipe).

Soil conditions allowing use of 3 feet of drain-rock beneath the perforated pipe would result in **6ft² of absorption area per lineal foot of trench** (3ft² x 2 = 6ft² ; trench has two sidewalls – see Figure 1, below).

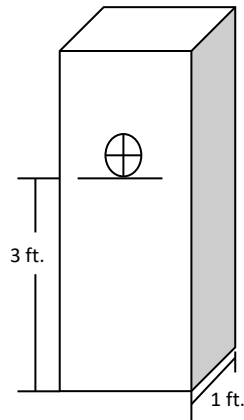

Figure 1 – Dispersal Field Trench Section illustrating 6 ft² of effective absorption area per lineal foot of trench

- c. With 6ft² absorption area per lineal foot of trench, the 900ft² of required absorption can be achieved by a dispersal field length of 150 feet. (Simply divide 900ft² by 6ft² per lineal foot which gives 150 lineal feet of trench; again the ft² units cancel.

2.3.3 Dispersal Field Sizing – Gravel-less Chambers

Gravel-less chambers may be suitable for certain sites. The dispersal field is sized similarly to graveled trenches, however the width of the dispersal trench bottom shall be considered as the effective absorption area per lineal foot of trench. For example: a trench 50 foot in length containing 3 foot wide chamber sections would yield a total of 150 ft² effective absorption area.

2.3.4 Dispersal Field Siting

Gravity flow dispersal trenches shall be placed within native soils; the use of fill materials is prohibited.

All dispersal trenches shall be oriented parallel to the natural ground contour.

Trench depth shall not exceed five (5) feet; with a maximum gravel column height of four (4) feet.

Trench width shall not exceed two (2) feet when drain-rock is used in trenches; the maximum trench width for use of gravel-less chambers is three (3) feet.

Trench spacing shall be twice the trench depth as measured from the centerline of the trench but shall never provide less than 3 feet between subsequent trench walls.

Dispersal field trenches shall not exceed seventy (70) foot in length.

Effluent shall be evenly distributed among trenches by use of DEH-approved distribution boxes that may be equipped with speed levelers or comparable devices.

Dispersal fields and tanks shall meet minimum horizontal separation distance from structures, property lines, surface waters, wells, steep slopes, public water intakes, and

other physical site features. The complete list of setback requirements is provided in Appendix E.

2.3.5 Ground Slope and Stability

Natural ground slope in all areas intended for dispersal field placement shall not exceed 30 percent. All soils to be utilized for dispersal field placement shall be stable. DEH may require slope stability reports from qualified professionals for sites exhibiting unstable landform features.

2.3.6 Soil Depth

Soil depth is measured vertically to the point where bedrock, hardpan, impermeable soils or saturated soils are encountered. Soils tested with percolation rates faster than 60 minutes per inch shall have a minimum of 3 feet of soil depth below bottom of trench.

In cases where there is at least 3 feet of soil beneath the trench bottom and soil percolation rates are slower than 60 minutes per inch a Non-standard OWTS will be required (see section 2.4).

In no case shall any type of OWTS be placed where there is less than 2 feet of unsaturated soil beneath the bottom of the dispersal area and/or where soils have a percolation rate slower than 120 minutes per inch.

2.3.7 Depth to Groundwater

The minimum depth to groundwater required below the bottom of the dispersal trench is determined based on the combined percentage of silt and clay occurring in the soil below the proposed trench bottom.

As shown in Table 3, where soils contain a combined percentage of **silt and clay of 5% or less, a 40 foot separation** between the trench bottom and seasonal high groundwater is required to protect groundwater. Where soils contain **15% or greater combined silt and clay, a 5 foot separation** between the trench bottom and seasonal high groundwater is required.

FIGURE 2 MINIMUM DEPTH TO GROUNDWATER BELOW LEACHING TRENCH

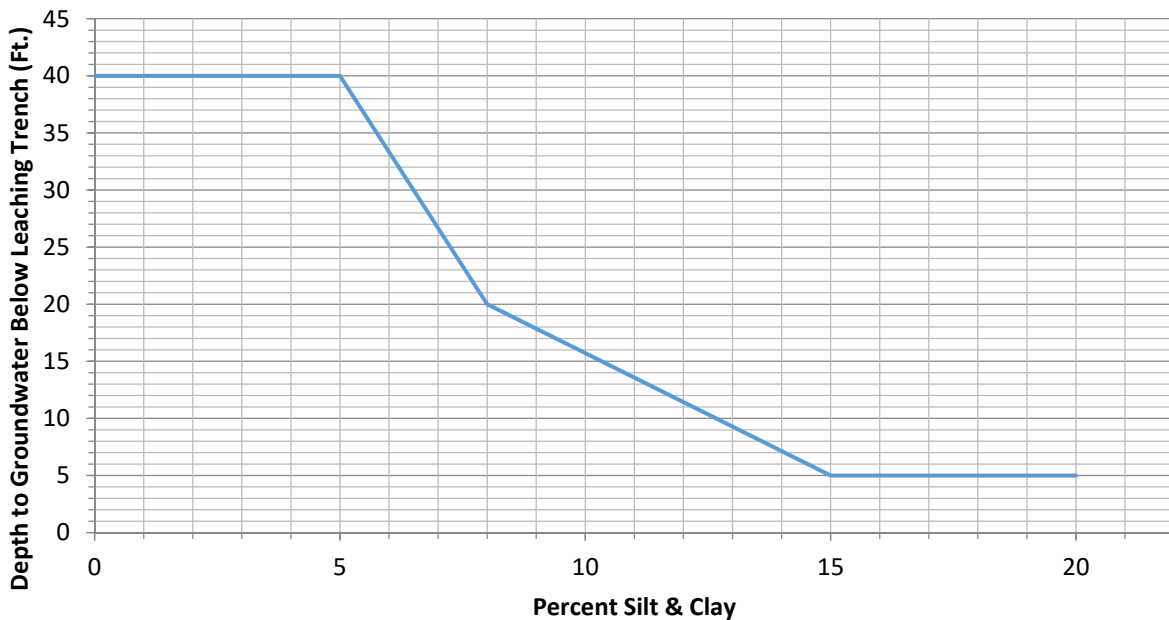

2.3.8 Replacement Area

A suitable area to accommodate the installation of a replacement OWTS equivalent to and separate from the initial dispersal system shall be demonstrated as a condition of OWTS permit approval or subdivision parcel approval. Replacement area sizing shall accommodate a system designed appropriately for the soil conditions identified during testing. The area designated for the replacement OWTS shall meet the required horizontal setbacks and remain unencumbered and undisturbed.

2.4 Non-Standard OWTS

The use of gravity-flow dispersal fields is not feasible in many areas of the county due to the occurrence of one or more of the following conditions:

1. Soil Percolation rates slower than 60 minutes per inch.
2. Seasonal high groundwater within three (3) feet of the dispersal field trench bottom.
3. Restrictive or impermeable soil layers such as hardpan or cementation etc. within three (3) feet of the dispersal field trench bottom.
4. Rapidly permeable coarse soils with percolation rates faster than five (5) minutes per inch.

On certain parcels where site conditions listed above prevent the use of a gravity-flow dispersal field a **Non-Standard OWTS** may be considered if a Qualified Professional can demonstrate that the following minimum requirements are met:

1. Soil percolation rates are not slower than 120 minutes per inch.
2. Seasonal high groundwater is at least 24 inches below the dispersal field trench bottom or basal area.
3. Restrictive soil layers such as hardpan or cementation are at least 24 inches below the dispersal field trench bottom or basal area.
4. Setbacks described in Appendix E are maintained.
5. Surface and ground water will not be impacted.

Non-standard OWTS normally require the use of a pump chamber, effluent pump and electrical appurtenances to achieve uniform discharge of effluent into a dispersal area. Because of the increased oversight and maintenance necessary, Humboldt County maintains an operating permit and inspection program for all non-standard OWTS. HCC Title VI Div 1 Chapter 6 sets forth requirements for the program. Upon installation of a non-standard OWTS, a property owner will receive notification of enrollment in the program. An inspection once every three years is required to maintain an operating permit to confirm proper operation.

As detailed in the following sections, the common Non-standard OWTS used in Humboldt County include:

- Pressure Distribution - shallow in-ground trenches with pressurized discharge
- Wisconsin Mound - dispersal occurs into an above ground mound of specialized sand
- Wisconsin At-Grade - dispersal occurs in a low gravel bed on the ground surface
- Supplemental Treatment – wastewater treated to prescribed levels prior to dispersal

Proposals for non-standard systems other than those listed above may be considered if sufficient information is provided to demonstrate compliance with minimum site conditions described above and adequacy of the system for the proposed application. A statement from a qualified service provider indicating a service contract can be established for the ongoing operation and maintenance of the system may also be required.

2.4.1 Pressure Distribution Systems

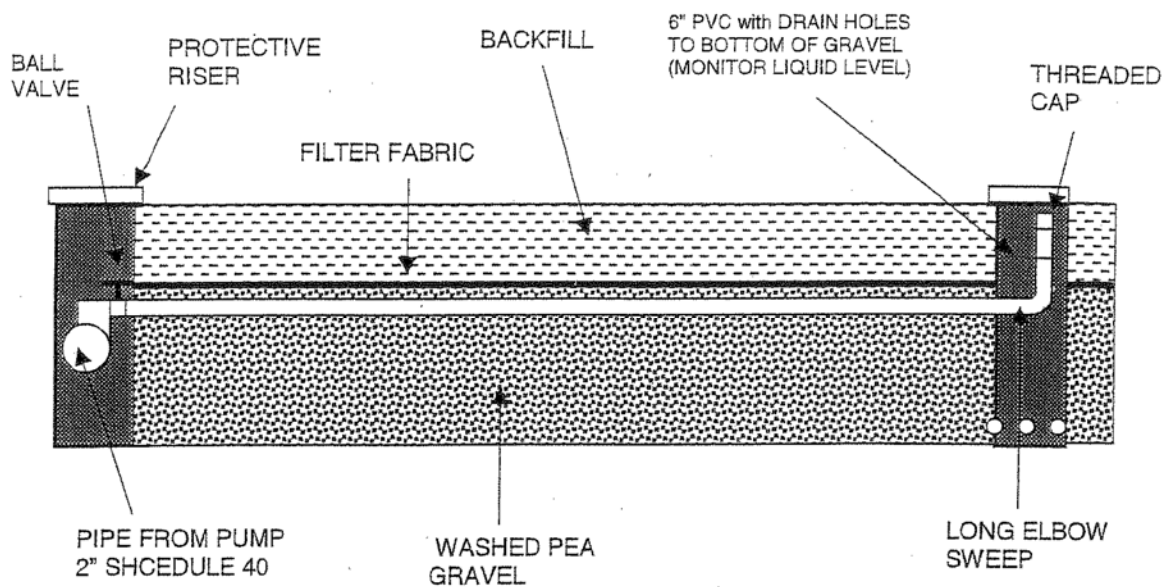

Figure 3 - Typical Pressure Distribution System

A pressure distribution system may be used if the following criteria can be met:

- A minimum of twenty four (24) inches of unsaturated permeable soil exists between the trench bottom and high groundwater.
- A minimum of twenty four (24) inches of unsaturated permeable soil exists between the trench bottom and impermeable soil such as hardpan, fractured or consolidated rock, etc.
- Percolation rates must not be slower than 120 minutes per inch.
- The native ground slope shall not exceed 30%

The design of the Pressure Distribution dispersal field shall be based on both the estimated peak daily flow and soil application rates from Table 3, *Pressure Distribution Soil Application Rates*.

Table 3 - Pressure Distribution Soil Application Rates

Percolation Rate (MPI)	Soil Application Rate (GPD/ft. ²)
5	0.732
10	0.554
15	0.481
20	0.425
25	0.389
30	0.363
35	0.344
40	0.323
45	0.305
50	0.296
55	0.285
60	0.277
70	0.243
80	0.211
90	0.179
100	0.147
110	0.115
120	0.083

The **effective absorption area** credited per **lineal foot** of pressurized dispersal trench shall be calculated by adding the bottom width of the trench to the total height of sidewall beneath the pressurized pipe; **not to exceed 5 ft.² effective absorption area per lineal foot of trench.**

Figure 4

Example: An 18 inch wide trench with 18 inches of sidewall beneath the pressurized pipe yields 4.5 ft.² of absorption area per lineal foot.

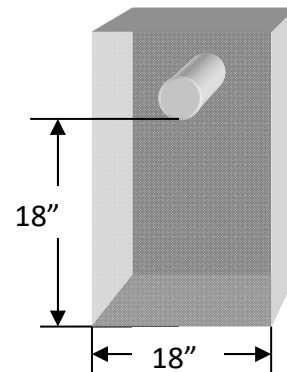

Soil application rates for sizing pressure distribution systems shall be based on percolation testing and/or textural analysis of the most restrictive soil group encountered below the pressurized dispersal pipe including the 24 inch soil column beneath the trench bottom.

A complete design shall include the following information:

- a. A site plan showing accurate location details of all system components
- b. The length of laterals and transport line shall be provided
- c. Pump chamber detail showing float switch locations, elevations etc.
- d. Size and type of all piping, valves, fittings and lateral access ports

- e. A dimensioned cross section of the pressurized dispersal trench
- f. Pump selection including pump curve
- g. Pump Control details
- h. Location and design of, at least, three (3) permanent performance wells of a depth equal to the proposed leach trench: (1) centered 10' upslope of highest pressure line, (2) centered 75% down the leachfield, (3) 25' downslope of the lowest pressure line.
- i. Any other information deemed necessary by DEH.

2.4.2 Wisconsin Mound System

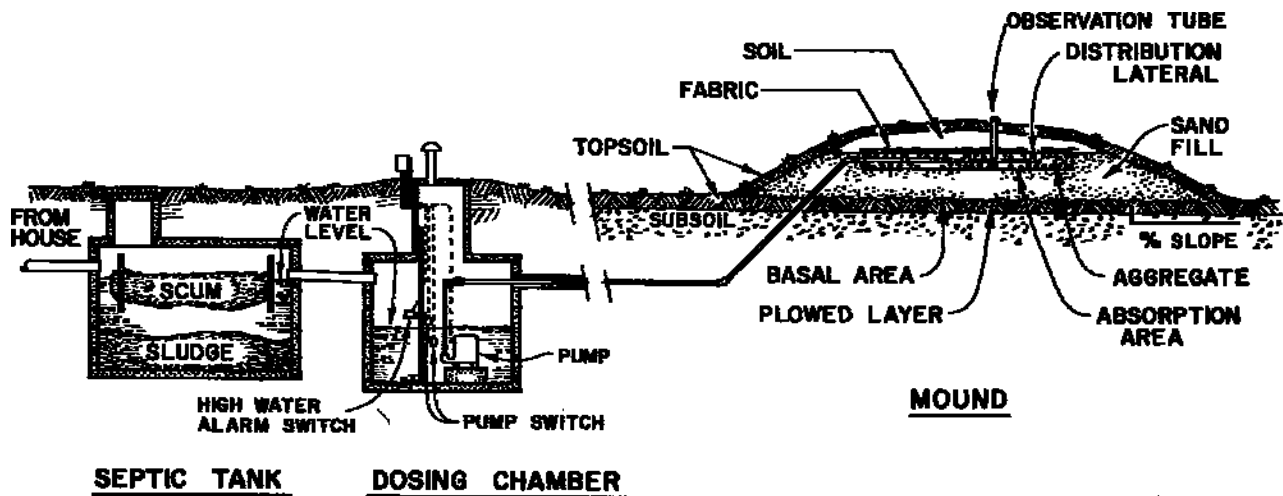

Figure 5 - Typical Mound System

A Wisconsin Mound requires a minimum of 24 inches of separation between high groundwater and basal area (ground surface).

Percolation rates shall not be slower than 120 minutes per inch.

Three (3) percolation test holes are required for the design of both the primary and reserve mound areas.

Installation is limited to slopes no greater than 12 percent.

Specifications and design for a Wisconsin Mound shall be based on the *Design and Construction Manual for Wisconsin Mounds, Small Scale Wastewater Management Project, Univ. of Wisconsin (January 2000)*.

2.4.3 At-Grade Systems

Cross Section of Wisconsin At-Grade System

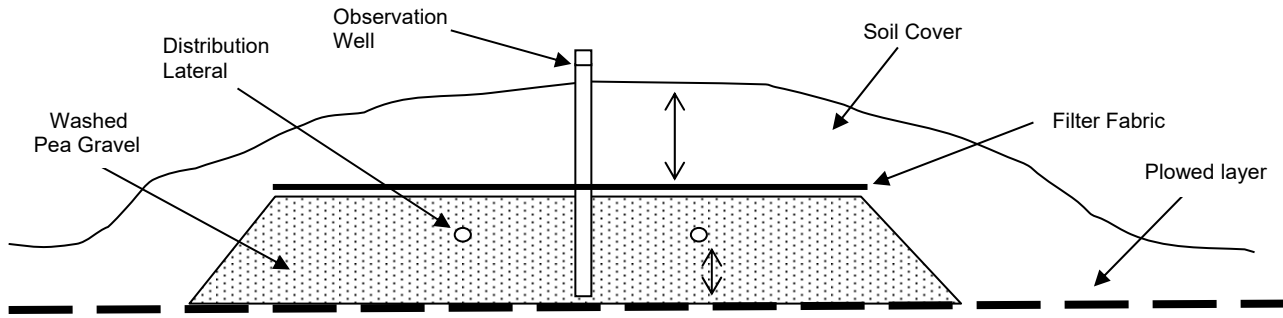

Figure 6 - Typical At-Grade System

At-Grade systems shall have a minimum separation between seasonal high groundwater and the basal area (ground surface) of 36 inches.

Percolation rates shall not be slower than 120 minutes per inch.

Maximum ground slope for installation is 25%.

Specifications and design for a Wisconsin At-Grade system shall be based on the *Wisconsin At-Grade Soil Absorption System Siting, Design and Construction Manual, Univ. of Wisconsin (January 1990)*.

2.4.4 Supplemental Treatment Systems

Supplemental Treatment is defined in the OWTS policy as “any OWTS or component of an OWTS, except a septic tank or dosing tank, that performs additional wastewater treatment so that the effluent meets a predetermined performance requirement prior to discharge of effluent into the dispersal field”. Supplemental treatment levels for Nitrogen and pathogens shall meet or exceed the criteria in Sections 10.9.1 and 10.10.1 of the State OWTS Policy:

Supplemental Treatment Requirements for Nitrogen

10.9.1 Effluent from the supplemental treatment components designed to reduce nitrogen shall be certified by National Sanitation Foundation (NSF), or other third party tester, to meet a 50 percent reduction in total nitrogen when comparing the 30-day average influent to the 30-day average effluent.

Supplemental Treatment Requirements for Pathogens.

10.10.1 Supplemental treatment components designed to perform disinfection shall provide sufficient pretreatment of the wastewater so that effluent from the supplemental treatment components does not exceed a 30-day average Total Suspended Solids of 30mg/l and shall further achieve an effluent fecal coliform concentration less than or equal to 200 Most Probable Number(MPN) per 100 milliliters.

A Supplemental Treatment system may be considered and/or required under the following conditions:

1. New or replacement OWTS within Tier 3 Advanced Protection Management Program areas (see Tier 3 and Figures 1-5 of LAMP).
2. New construction, repair or replacement OWTS on parcels where unfavorable site conditions necessitate a level of treatment greater than a standard (gravity) OWTS or other non-standard OWTS can provide.
3. New construction, repair, or replacement OWTS on parcels with unfavorable site conditions where the surrounding environment requires enhanced protection.

Any supplemental treatment system proposed for use must have undergone testing and certification from a recognized independent third party testing laboratory, such as NSF. Any supplemental treatment system proposed shall be listed by testing organization and treatment standards. Listing standards include but are not limited to:

NSF Standard 40 – Residential: Onsite Systems

NSF Standard 245 – Nitrogen Reduction

NSF Standard 46 – Components and Devices

The target treatment criteria for a specific supplemental treatment system (bacteria, nitrogen or both) will depend on site specific conditions.

Any application for a supplemental treatment system must be prepared by a Qualified Professional competent in the design of such systems.

All supplemental treatment systems require regular service and maintenance by a qualified service provider. The OWTS application must propose an appropriate ongoing monitoring schedule for the system. The permit, with the design approved by DEH will include the approved monitoring schedule. Prior to DEH issuing construction approval, a copy of a signed maintenance contract with a Qualified Service Provider to perform the required maintenance and monitoring for a duration of, at least, three (3) years must be provided.

2.5 Intercept Drains (Curtain Drain)

1. Intercept drains are gravel filled trenches with perforated pipe installed up gradient from the dispersal field area for the purpose of intercepting, diverting, and discharging perched groundwater away from the dispersal field. The use of an intercept drain may be proposed in conjunction with a site specific OWTS design requiring perched groundwater to be lowered.
2. The use of an intercept drain to lower perched groundwater for the purpose of establishing a dispersal field will be considered when all of the following criteria can be met:
 - a. The native ground slope exceeds 5%.
 - b. Soil profile examination shows the presence of impermeable material upon which groundwater will perch.
 - c. The trench bottom of the intercept drain can be tied into the impermeable material.
 - d. Monitoring to demonstrate that the intercept drain is lowering of the perched water level sufficiently for the intended dispersal field is required. This shall be accomplished through the placement of monitoring wells in the area between the intercept drain and the upper most portion of the dispersal field.
 - e. No portion of an intercept drain shall be located less than 15 feet up gradient, 25 feet laterally, or less than 50 feet down gradient from any septic tank or dispersal field, replacement area, or less than 5 feet from any property line.

2.6 Design Submittal

A complete site evaluation and OWTS design package is required for all applications, must be signed and stamped by the Qualified Professional, and shall include the following elements:

1. Project description explaining the intended use or uses of the property; indicate the number of dwelling units and total number of bedrooms. If a nonresidential use is proposed, an estimate of the quantity of sewage flow and the method used to arrive at the estimate shall be provided.
2. General description of the waste stream; indicate if the system will be serving a single-family residence, multiple structures, commercial or industrial uses.
3. Project Location providing detailed directions with map and instructions to access property.
4. A scale map of the lot showing: appropriate landmarks; steep slopes; roads; surveyor's landmarks; lot dimensions; existing and proposed easements for road or utility purposes; wells, water bodies or drainage swales; and existing, proposed, or abandoned onsite wastewater treatment systems.

5. A scaled site plan or detail of the proposed OWTS showing the area of the work, the average cross slope, the structure served, roads, parking areas, and all items in 4 (above) within 150 feet of the project.
6. Site description stating the landform type, geologic features or formation encompassing the area of the proposed dispersal field. Indicate landscape/drainage features (such as rock outcrops, erosion or artificially disturbed areas) which occur in the vicinity of proposed OWTS.
7. Complete Site Evaluation Worksheet (Appendix F).
8. A written summary of the site evaluation results and all soils testing (profile description, percolation testing, and groundwater data) with findings presented in a legible format.
9. Explanation of proposed OWTS Design.
10. Complete OWTS design calculations.
11. Appropriate, most current design manuals referenced where applicable.
12. Detailed schematic drawings and specifications for all OWTS Components.
13. Installation Instructions for proposed OWTS.
14. Design submittals to permit OWTS previously installed without a permit shall also include details of the installed system including the size and condition of the septic tank; length, depth, spacing, and type of dispersal trenches; determination of adequate sizing; and recommendations for modifications necessary to meet the requirements of these regulations.

PART 3 - Permitting

Humboldt County Code (HCC) section 612-2.

(a) *“Permit Required. No person shall construct, reconstruct, repair, abandon, operate or excavate for any kind of onsite wastewater treatment system or any portion thereof without having first obtained a permit to do so from the Health Officer.*

Application forms and current fee sheets can be provided upon request in hard copy or electronic format, are available at the DEH office, and can be found online at <http://www.humboldt.gov/730/Land-Use-Program>.

An approved application is valid for one year from the date of the approval (one year from the date of Building Permit issuance for new construction). If the work has not been completed within that time, the applicant may request in writing a 1-year extension. Such request must state that the construction is expected to be completed within one year and that the project has not changed. Extensions require a minimal fee, are valid for one year; only one extension will be granted. Making this request after a permit has expired constitutes a Permit Renewal and is subject to additional cost.

3.1 New Construction

NOTE: New construction proposed within the variance prohibition area(s) requires DEH presence during site soil investigation.

OWTS Permit application packages must be submitted to Humboldt County Building Division at 3015 H Street, Eureka. Applicants have two options:

The first option requires the applicant to provide an OWTS design proposal based on a site evaluation conducted by a Qualified Professional. The site evaluation and OWTS design proposal must be submitted with the OWTS permit application.

The second option allows the applicant to have DEH staff meet onsite with a backhoe (provided by the applicant) to conduct a site evaluation. The OWTS permit application must be submitted to the Building Division prior to DEH meeting onsite. If there are sufficient depths of well drained Zone 2 soils found in the backhoe excavations, DEH staff can complete a site evaluation, prepare an OWTS design and approve the permit application provided all other siting criteria are met.

Note: If backhoe excavations reveal clay rich soils and/or indications of high groundwater the applicant must employ a Qualified Professional to complete wet weather soils testing, design and submit an OWTS application package.

The Building Division will forward the application to DEH for review. All applications will be field inspected. If questions arise, DEH will contact the applicant. When the application package is approved, it will be returned to the Building Division to be issued as part of the Building Permit. In cases where DEH is unable to approve a permit application, the applicant will be provided a written explanation for the permit denial.

3.2 Repair Permit

Owners of OWTS requiring a repair are encouraged to consult with DEH staff as soon as possible after noticing a failure. Repair designs must be prepared by a Qualified Professional as defined in Part 1.

Applications must be submitted to the DEH (not the Building Division) with the appropriate fee.

1. DEH may design standard and non-standard OWTS repairs on sites that support simple repairs. If a site qualifies for a "DEH prepared OWTS repair permit", DEH staff will conduct a site evaluation and prepare a design to conform as closely as possible to current standards. Difficult sites require the applicant to secure the services of a Qualified Professional outside DEH to perform testing and/or OWTS design work.
2. An application for a repair permit shall only propose changes to a failing OWTS serving an existing structure; it shall not propose changes to accommodate increased development or intensified use of the property.
3. Repair permits submitted in association with property transactions must include a description of the testing performed to identify the failure. The repair must be designed by a Qualified Professional.
4. A copy of the approved OWTS repair permit and system design/plans will be sent to the applicant. Issued repair permits are valid for 12 months from the date of approval.
5. Only plans approved by DEH may be used for an OWTS repair. A copy of the signed, approved plans shall be kept on site during all phases of repair construction.

3.3 Modification Permit

Individuals shall obtain an OWTS **modification** permit when an **existing** OWTS is not suitable or sized appropriately to accommodate a current or proposed use. This policy applies when there is an existing OWTS, which is not exhibiting signs of failure.

Examples of an OWTS modification include the following:

1. The addition or replacement of a septic tank, pump chamber or grease trap.
2. The addition or replacement of distribution boxes, valves or components of a non-standard OWTS.

3. The addition or reconfiguration of dispersal field trenches supported by valid soils testing.

Development of secondary dwelling units, multi-family dwellings or commercial facilities to be served by an OWTS may require more extensive evaluation and design than is appropriate to the scope of a **modification** permit. In those instances, application and payment for new construction of an OWTS will be required.

Any new or replacement component installation shall conform to and the requirements of Part 4, Construction and Installation.

Procedure:

1. If the OWTS modification is associated with a building permit, applicants shall apply for the OWTS **modification** permit at the Humboldt County Planning & Building Department, Building Division and pay the appropriate fee.
2. If the OWTS modification permit is not associated with other work permitted through the Planning and Building Department, applicants shall apply for the permit directly through DEH.
3. DEH will review the modification permit application and evaluate the **application** in accordance with the *Policy on the Use of Existing OWTS*, Appendix F to determine if sufficient information is available to proceed with a modification or if additional soils testing is required.
4. In the absence of soil testing data and an installation permit for the existing system, soil testing shall be completed as outlined in the *Policy on the Use of Existing OWTS*.
5. Once DEH staff determines sufficient information exists, and site has capacity to support proposal DEH will prepare plans for the modification.. In cases where an OWTS modification has been prepared by a qualified consultant DEH will review the proposal for compliance with applicable state and county regulations.
6. When the Modification Permit Application and plans are approved by DEH, they will be issued from DEH or sent back to the Building Division to be issued as appropriate. Approval of installation is valid for 12months from the date of issuance.

3.4 OWTS Installed Without Permit

1. Applicants seeking an OWTS permit (in conjunction with a residential building permit) for a system installed without the benefit of agency review/approval may submit an OWTS permit application through the Humboldt County Building Division with the appropriate **consultant prepared** fee (either Standard or Non-standard depending upon the OWTS as-built). The application shall include site evaluation and soils testing

information completed by a Qualified Professional and an as-built description of the OWTS. Wet Weather soils testing may be required for certain parcels.

2. DEH staff shall review the information submitted for conformance to applicable siting/design criteria.
3. If DEH determines that the OWTS as-built description or design proposal submitted is adequate a site inspection will be scheduled. The applicant will be asked to expose portions of the system including but not limited to the septic tank, distribution box and ends of dispersal field lines. If the system utilizes a pump, the pump chamber will need to be exposed.
4. DEH shall inspect the site to determine if the site and system installation is adequately represented in the submittal package and if it complies with siting and design requirements.
5. If the DEH inspection finds the OWTS installation and site conditions reported are in compliance with siting and design requirements, the permit application shall be approved. Note: Construction approval of the OWTS permit shall not be granted until the actual building permit for the project has been issued.
6. If an OWTS installation or the site conditions do not meet siting and design requirements, DEH shall provide the applicant with written notification of the deficiencies found and corrective measures needed to obtain approval.

3.5 Structure Remodel, Replacement or Change in Use

The use of an existing OWTS for new or remodeling construction or changes in use, will be acceptable if it can demonstrated with acceptable documentation or site inspections that the OWTS septic tank and dispersal field are sized appropriately and functioning properly for the expected daily wastewater discharge of the proposed project, and a 100% reserve dispersal field area is available. Remodeling construction which will not increase the daily wastewater discharge or impact the availability of a 100% reserve dispersal field area can be approved with an existing OWTS provided there are no detectable signs of system failure.

Determinations will be made in accordance with the *Policy for the Use of Existing OWTS*, Appendix F. Generally for a proposed remodel, structure replacement, or change in use, DEH must be able to determine the following:

- Soil testing and groundwater elevation information as described in Part 1 of this document is available for the existing OWTS and designated reserve area.
- The existing OWTS is sized and installed appropriately to support the proposed project.
- Reserve area is not impacted by the proposed project.
- The existing OWTS is functioning properly with no evidence of failure.

If the project has the potential to increase the wastewater flow to the existing OWTS, the owner shall apply for a Modification Permit to make necessary improvements to an existing system.

3.6 Septic Tank Destruction/Abandonment

Abandoned septic tanks shall be destroyed in accordance with HCC 611-6.

- (a) Every abandoned building sewer or part thereof shall be plugged or capped in an approved manner within five feet (5') of the property line.*
- (b) Every abandoned septic tank shall have the sewage removed therefrom and be completely filled with earth, sand, gravel, concrete, or other approved material. The cover of the septic tank shall be removed before filling. The filling shall not extend above the top of the vertical portions of the sidewalls or above the level of any outlet pipe until an inspection has been completed by the Health Officer. After such inspection the septic tank shall be filled to the level of the top of the ground.*
- (c) No person owning or controlling any septic tank shall fail, refuse, or neglect to comply with the provisions of this section upon receipt of notice from the Health Officer.*
- (d) Where an OWTS is abandoned consequent to connecting with a public sewer, the property owner or his/her authorized representative making the connection shall fill the abandoned septic tank as required by the Health Officer within thirty (30) days from the time of connecting to the public sewer.*

Procedure:

1. If the septic tank destruction is associated with a building permit, applicants shall apply for the **Septic Tank Destruction** permit at the Building Division and pay the appropriate fee.
2. If the septic tank destruction is not associated with other work permitted through the Planning and Building Department, applicants shall apply for the permit directly through DEH.

3.7 Grease Interceptors

All structures served by an OWTS that produce wastewater containing oil, wax, fats or grease shall utilize an approved grease interceptor. Plumbing fixtures having the potential to receive fats, oils, wax, and/or grease shall be connected to the grease interceptor. These include, but are not limited to:

- Three compartment sinks
- Floor sinks
- Mop sinks
- Some dishwashing machines

Toilets, urinals, showers, and similar fixtures shall not discharge through an interceptor.

Any facility served by an OWTS, except those serving drinks and/or prepackaged food only, must demonstrate to the satisfaction of DEH that an adequate grease interceptor is in use prior to approval of an operating permit and/or business license.

For new construction, the grease interceptor shall be permitted as a component of the OWTS in accordance with the procedure outlined in section 3.1. Existing structures served by permitted OWTS shall obtain a Modification Permit for the addition of a grease interceptor. Note that any necessary changes to existing interior plumbing are permitted through the Humboldt County Planning & Building Department.

3.8 Additional Considerations

3.8.1 Holding Tanks

The use of holding tanks is prohibited except where DEH determines that:

1. It is necessary to abate an existing nuisance or health hazard; or
2. It is for transient use at a campground or similar public facility where use of a permanent OWT is not feasible and maintenance is performed by a public agency or similar entity.

3.8.2 Cumulative Effects

The potential cumulative effects on ground and surface waters from OWTS usage include, but are not limited to, groundwater mounding and nitrate loading. The need for a cumulative impacts study will be considered for development served by OWTS when one or more of the following situations occur:

- The anticipated daily flow exceeds 1500 gallons.
- Wastewater strength exceeds that of domestic wastewater.
- OWTS is located in an area where site conditions increase potential for contamination.
- OWTS is located in close proximity to multiple existing OWTS with cumulative flows in excess of 1500 gallons/day.
- Other situations as deemed necessary.

Groundwater Mounding Analysis

Groundwater mounding analysis shall be used to predict the highest rise of the water table and shall account for background groundwater conditions during the wet weather season. The maximum acceptable rise of the water table for short periods of time during the wet season, as established from groundwater mounding analysis, shall be as follows:

- For systems with design flows of less than 1500 gallons per day, groundwater mounding beneath the dispersal field shall not result in more than a 50 percent reduction in the minimum depth to seasonally high groundwater as specified in these regulations.

- For systems with design flows exceeding 1500 gallons per day, a minimum groundwater clearance of 24 inches shall be maintained beneath the dispersal field trench bottom.

Nitrate Loading

Analysis of nitrate loading effects shall be based, at a minimum, on an estimate of annual chemical-water mass balance. Minimum values used for the total nitrogen concentration of septic tank effluent shall be: 40 mg/l as N (for average flow conditions) for residential wastewater, or as determined from sampling comparable systems or from acceptable scientific literature. OWTS shall not cause the groundwater nitrate concentration to exceed 10.0 mg/l as N at any source of drinking water on the property nor on any potential off-site drinking water source.

3.8.3 Variance Policy

If a proposed design cannot meet any standard contained in the Humboldt County OWTS Regulations and Technical Manual or applicable state policy, the application must identify the unmet standard. For DEH to consider a variance to any standard, the applicant must submit an OWTS Variance Application. Variances may be granted when the applicant can demonstrate that water quality will not be impaired and public health will not be impacted as a result of the variance. Variances cannot be granted to parcels within the Variance Prohibition Area(s).

3.8.4 Limitations

The following conditions are regulated by the RWQCB. Owners must notify the RWQCB via submittal of a Report of Waste Discharge, Form 200, available from the RWQCB.

- a. A new or replacement OWTS that does not meet the conditions and requirements set forth in these regulations;
- b. any OWTS, not under individual waste discharge requirements or a waiver of individual waste discharge requirements issued by a Regional Water Board, with the projected flow of over 10,000 gallons-per-day;
- c. any OWTS that receives high-strength wastewater, unless the waste stream is from a commercial food service building;
- d. any OWTS that receives high-strength wastewater from a commercial food service building: (1) with a BOD higher than 900 mg/L, or (2) that does not have a properly sized and functioning oil/grease interceptor.

PART 4 - Construction and Installation

4.1 General Installation Requirements

1. Only a qualified professional shall design all new/replacement Onsite Wastewater Treatment Systems (OWTS) and modifications to existing OWTS where the treatment or dispersal system will be expanded. A qualified professional employed by a local agency, while acting in that capacity may design or review and approve a design for a proposed OWTS.
2. A Licensed General Engineering Contractor (Class A), General Building Contractor (Class B), Sanitation System Contractor (Specialty Class C-42), or Plumbing Contractor (Specialty Class C-36) shall install all new OWTS and replaced OWTS in accordance with California Business and Professions Code Sections 7056, 7057, and 7058 and Article 3, Division 8, Title 16 of the California Code of Regulations. A property owner may also install his/her own OWTS under approval of DEH with the provision that the components remain exposed for inspection and approval by DEH.
3. OWTS shall be installed in accordance with the design plans approved by the Division of Environmental Health (DEH). Any proposed changes to approved plans must be reviewed and re-approved through DEH.
4. All wastewater from each building or place shall be discharged into an approved OWTS or approved graywater system (Appendix G), where applicable.
5. No OWTS, or part thereof, shall be located on any lot other than the lot which is the site of the building or structure served by such system.
6. No rain, surface, or subsurface water shall be connected to or discharged into any OWTS.
7. The OWTS shall start at a point two (2) feet from the foundation of a building or outside wall of a mobile home.
8. OWTS shall not be permitted under walks, driveways, parking lots, surface roadways, compacted soils or gravel in most cases. Variance to this requirement may require aerobic pretreatment.
9. All dispersal systems (leach fields) shall be covered with at least twelve (12) inches of soil.

4.2 Building Sewer Requirements

1. Type and size of building sewers used in OWTS shall be in accordance with the most recent revision of the California Uniform Plumbing Code, as adopted by the County of Humboldt.
2. Building sewers shall be run in practical alignment and at a uniform slope of not less than one-fourth (1/4) inch per foot toward the point of disposal. Where it is impractical, due to the depth of the street sewer or to the arrangement of any building or structure, to obtain a slope of one-fourth (1/4) inch per foot, a slope of not

less than one-eighth (1/8) inch per foot may be approved by DEH if the building sewer is at least four (4) inches in diameter.

3. Building sewer piping shall be laid on a firm bed throughout its entire length. Any such piping placed on fill shall be laid on a bed of approved materials and shall be adequately supported to the satisfaction of DEH.
4. There shall be a minimum of twelve (12) inches of earth fill over all building sewers.
5. Cleanouts shall be placed in every building sewer at the junction with the building drain and at intervals not to exceed one hundred (100) feet in straight runs.
6. Every change in alignment or grade in excess of twenty-two and one-half (22 ½) degrees in a building sewer shall be served by a cleanout.
7. Each cleanout shall be installed so that it opens in a direction opposite to the flow of sewage or waste or at right angles thereto and vertically above the flow of the pipe.
8. Cleanouts installed under concrete or asphalt paving shall be made accessible and shall be adequately protected.
9. Approved manholes may be installed in lieu of cleanouts if approved by DEH.
10. Gravity building sewers constructed of materials approved for use within a building may be located within the same trench as a private water line as long as the water line is installed above all sewer lines. Existing sewer lines constructed of materials not approved for use within a building must maintain a one (1) foot vertical and one (1) foot horizontal separation to all water lines.
11. Pressure sewer lines shall be installed in a separate trench at least one (1) foot horizontally from the water line trench.

4.3 Septic Tank Requirements

1. New and replaced septic tanks shall be limited to those approved by the International Association of Plumbing and Mechanical Officials (IAPMO) or stamped and certified by a California registered civil engineer as meeting the industry standards and their installation shall be in accordance with manufacturer's instructions.
2. New septic tanks shall be designed to prevent solids in excess of three-sixteenths (3/16) of an inch diameter from passing to the dispersal system. Septic tanks that use a National Sanitation Foundation/American National Standard Institute (NSF/ANSI) Standard 46 effluent filter shall be deemed in compliance with this requirement.
3. Septic tanks shall be of two-compartment construction having watertight risers over each access opening with riser tops set within 6 inches of finished grade. The first compartment shall be twice the capacity of the second.
4. The outlet and inlet shall be at least equal in diameter to the building sewer pipe.
5. Septic tanks shall be water and odor tight.
6. Septic tanks shall be sized according to the Septic Tank Sizing Chart, Section 2.2.
7. All septic tanks shall be equipped with an effluent filter located in the outlet compartment in such a manner to be easily serviced.
8. Reinforced concrete, standard weight reinforced concrete blocks or similar material not subject to excessive corrosion or decay and which will produce a water-tight tank shall be used.

9. Wood and metal septic tanks are not acceptable.
10. Septic tanks shall be installed in a location that allows for practical access and servicing.
11. Excavations for all septic tanks shall be made according to tank manufacturer's requirements. Such excavations shall provide a level, uniform load bearing surface free of imbedded rock or boulders. Wet or unstable beds shall be over-excavated, backfilled and compacted with an approved material suitable to stabilize and support the tank.
12. The separation between any two tanks shall be at least two (2) feet.
13. All septic tanks shall be completely watertight. DEH may require a watertight test on any new or existing septic tank. When required, the septic tank shall be filled to a level specified by DEH and left for twenty four (24) hours. Following the twenty-four (24) hour period the tank shall be refilled to the original level. If there is no measurable loss for one (1) hour, the tank is considered water-tight.
14. In some cases, DEH may require water-tight certification from the OWTS designer.
15. Septic tanks installed in areas of known seasonal groundwater at six (6) feet or less from original grade shall be made non-buoyant according to the manufacturer's recommendations or other methods approved by DEH.

4.4 Grease Interceptors

1. Grease interceptors shall be sized in accordance with the most current version of the California Plumbing Code, but shall not be less than 750 gallon capacity.
2. Grease interceptors shall be constructed and installed in accordance with Section 4.3 – Septic Tank Requirements except that the sanitary tees shall extend to a depth of 12 inches above the bottom of the tank. Effluent filters are not required.
3. All interceptors shall have risers installed over each access port.
4. Interceptors shall be located outside the structure and as close as possible to the fixtures served.
5. Grease interceptors shall be cleaned regularly to ensure proper operation. Cleaning shall be performed by a qualified grease pumper possessing applicable licenses and permits as issued by the State of California and the County of Humboldt.

4.5 Pump Tank / Pump / Control Requirements

1. The pump tank shall be single chamber, pre-cast concrete, and shall have the floors and walls of the tank monolithically poured. Other tanks may be approved for use if they can demonstrate current IAPMO approval listing.
2. The pump tank shall have a minimum capacity of 500 gallons. If site conditions prevent a tank of this size, other size proposals may be considered.
3. Concrete tanks shall be sealed with a heavy cement- based waterproof coating, Thoroseal or approved equal.
4. Excavations for tanks shall be in accordance with manufacturer's requirement. Such excavations shall provide a level, uniform load bearing surface free of imbedded rock

- or boulders. Wet or unstable beds shall be over-excavated, backfilled and compacted with an approved material suitable to stabilize and support the tank.
5. Tanks shall have adequately sized access opening with water-tight risers extending to the ground surface.
 6. Concrete tanks shall be tested for water tightness by the method described for septic tanks.
 7. Pump tanks installed in areas of known seasonal groundwater at six (6) feet or less from original grade shall be made non-buoyant according to the manufacturer's recommendations or other methods approved by DEH.
 8. A minimum two (2) foot separation shall be maintained between the pump tank and septic tank.
 9. Pump tanks shall receive clarified effluent that has been treated by a septic tank equipped with an effluent filter or other approved pretreatment device.
 10. Plans detailing the proposed use of a pump tank, pump and all appurtenant components complete with control switch elevations shall be prepared by a qualified professional and provided to DEH for review prior to permit approval.
 11. The emergency storage volume available in a pump tank shall be 150 gallons or 1/3 of the design flow, whichever is greater. The storage volume will be considered the liquid capacity between the invert of the inlet tee and the point of high water alarm activation.
 12. Dosing tanks shall be vented back through the septic tank, or have a separate vent.
 13. Only UL approved pumps designed for sewage effluent shall be used.
 14. The pump discharge line shall be equipped with a check valve designed for wastewater effluent unless the dispersal area is located down slope of the pump in which case a siphon relief hole shall be drilled in the discharge line.
 15. The pump shall be placed so that it remains submerged to allow for cooling and does not contact sewer gas. In no case shall the pump be set less than four (4") from the bottom of the tank.
 16. The connection between the pump and the force main shall allow for ease of pump removal and maintenance.
 17. Float control switches shall be UL and/or CSA listed and set securely in accordance with manufacturers' specifications. Switches shall not be attached to the pump discharge assembly.
 18. The high water alarm float switch shall be set to activate two (2") inches above the pump "on" switch.
 19. The alarm float switch shall activate an audible and visible alarm which remains on once activated until shut off by the property owner or maintenance personnel.
 20. The pump and alarm shall be powered by separate circuits.
 21. The pump, pump control panel and all associated components shall be installed as per the National Electrical Code (NEC) and inspected/approved by the local Building Department.
 22. Splice boxes shall be external to and attached to the tank riser, watertight, corrosion proof, resistant to UV exposure and adequately sized to accommodate multiple wiring configurations.

4.6 Distribution Boxes

1. In every dispersal field on level terrain an approved distribution box shall be used.
2. On sloping terrain distribution boxes shall be used and may require “speed levelers” or similar device to evenly distribute effluent.
3. The size and type of distribution box shall be included in design proposal.
4. Distribution boxes shall be set level on a competent base.
5. The use of more than one distribution box may be required in certain situations.
6. Wood and metal distribution boxes are unacceptable.
7. Other types of distribution boxes may be proposed for DEH approval.

4.7 Gravity OWTS

1. Gravity OWTS shall be a subsurface dispersal field (leachfield) designed using not more than 6 square-feet of infiltrative area per linear foot as the infiltrative surface. Trench width shall not exceed 3 feet.
2. Dispersal field trenches shall be placed in natural earth or properly prepared earth fill under approval of DEH.
3. Dispersal field trenches on sloping ground shall follow surface contours.
4. Dispersal field trenches shall not exceed seventy (70) feet in length.
5. The bottom of the dispersal field trench shall be level to within a tolerance of two (2) inches in 100 feet.
6. All smeared or compacted soil surfaces in the sidewalls or bottom of dispersal field trenches shall be scarified to the depth of the smearing or compaction and the loose material removed prior to placement of drain rock.
7. Dispersal field trenches shall be evenly filled with ¾” to 2-1/2” washed river rock, gravel or other approved hard rock. Rock that easily decomposes is prohibited.
8. Effluent sewer, header pipe, dispersal line and fittings shall be a minimum three (3) inch diameter, watertight and one of the following: (A) Schedule 40 PVC that meets the most current ASTM D-1785 for three (3) inch pipe and D-2672 for minimum four (4) inch pipe; (B) Schedule 40 Acrylonitrile-Butadiene-Styrene (ABS) that meets the most current ASTM Specification D-2468; (C) ASTM SDR 35 with solvent-welded or rubber-gasketed joints; or (D) Other material approved by the DEH.
9. The first five (5) feet of pipe extending from the septic tank and from the distribution box shall be solid, non-perforated pipe.
10. Perforated dispersal line shall have two (2) rows of holes spaced one hundred-twenty (120) degrees apart and sixty (60) degrees on either side of a centerline.
11. Dispersal field trenches shall not exceed a maximum depth of 5 feet as measured from the ground surface to the bottom of the trench.
12. All new OWTS shall have a 100 percent replacement area available that will serve the development if the primary dispersal field fails.
13. No dispersal field or replacement area shall be covered by any type of impermeable surface.

14. Once an OWTS is installed, the soils in the dispersal field area and replacement area shall remain undisturbed and not subject to vehicular traffic or confined animal use.
15. Setback requirements for conventional gravity OWTS are listed in Appendix E.

4.8 OWTS Construction Inspection

DEH staff inspectors shall perform OWTS construction/installation inspections to ensure conformance with applicable standards and all terms and conditions contained within the OWTS permit.

Installers shall provide at least 24 hours advance notice to DEH staff inspectors prior to reaching specified construction steps. Notification must include applicant's name, assessor parcel number and site location. Failure to provide sufficient notice may cause delays in the construction of the OWTS.

The inspection steps required for a particular OWTS installation will vary with the type and complexity of the approved OWTS design. Specific inspections required for Non-standard OWTS will be listed and included as part the approved permit.

DEH staff inspectors may combine one or more required inspections into a single site visit. The following inspections shall be required unless the applicant obtains DEH staff inspector's waiver of any inspections.

1. Preconstruction site visit to ensure proper OWTS layout.
2. Open trench inspection.
3. Septic Tank installation with risers and filter and/or pump tank and components where applicable.
4. Septic tank (Pump tank) water tight inspection.
5. Drain rock placement and piping connections from septic tank, distribution box etc.
6. Final Inspection

Electrical wiring for OWTS shall be completed under appropriate permit from the Humboldt County Building Division and will be inspected by Building Division staff.

Final inspection of the constructed OWTS occurs when all portions of the OWTS and all other construction features required by these standards or by permit conditions have been completed.

In certain cases, written verification from a Qualified Professional may be accepted and/or required in lieu of an inspection by DEH staff inspectors.

DEH staff inspectors shall sign and date the appropriate section of the OWTS permit upon satisfactory completion of inspections.

4.9 OWTS Operation and Maintenance

OWTSs benefit from routine maintenance and consideration of the types of wastes sent to them. DEH recommends the following practices to prolong the lifespan of OWTS and to prevent potential environmental impacts associated with their use:

- Only allow domestic wastewater to enter the system. Other substances such as pesticides, strong solvents, non-household chemicals, etc. can harm the septic tank and may contaminate groundwater.
- Avoid disposing of fats, oils, and greases to the OWTS. These substances can accumulate in dispersal field piping and receiving soils leading to OWTS failure.
- Inspect the depth of sludge in the septic tank every three years. Tanks should be pumped when the sludge layer is two or more feet thick.
- Dispersal fields, including reserve areas, shall be protected. Soil compaction can reduce their ability to receive wastewater. Do not drive vehicles, build, or place heavy equipment over dispersal field areas. Hoofed animals such as goats, sheep, horses, and/or cattle can compact soils and shall be prohibited from dispersal fields.
- Trees and shrubs shall not be planted in the dispersal area because roots can become invasive and cause clogging.
- Divert water run-off away from dispersal field areas.

APPENDIX A - SOIL PERCOLATION SUITABILITY CHART FOR OWTS

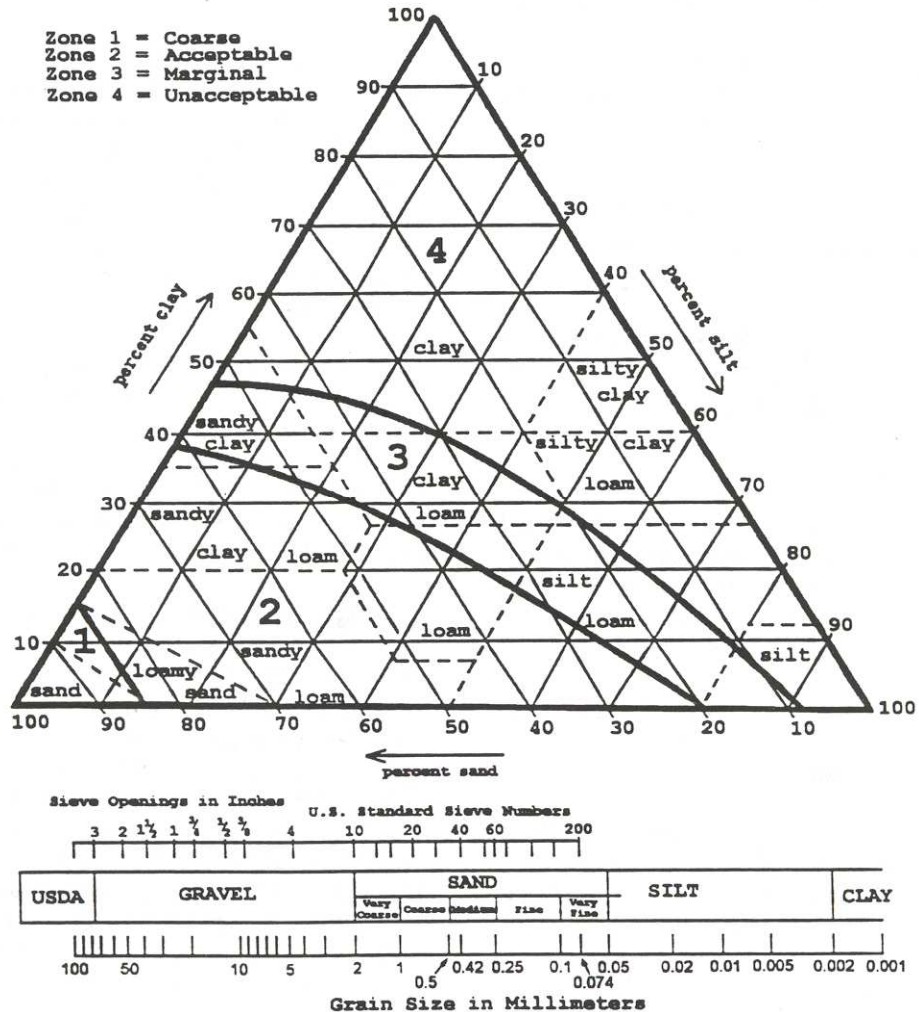

Instructions:

1. Plot texture on triangle based on percent sand, silt, and clay as determined by hydrometer analysis.
2. Adjust for coarse fragments by moving the plotted point in the 100 percent sand direction an additional 2% for each 10% (by volume) of fragments greater than 2mm in diameter.
3. Adjust for compactness of soil by moving the plotted point in the 100 percent clay direction an additional 15% for soils having a bulk-density greater than 1.7 gm/cc.

Note: For soils falling in sand, loamy sand, or sandy loam classification bulk density analysis will generally not affect suitability, and analysis is not necessary.

APPENDIX B

OBSERVATION WELL REPORTING LOG

(Example)

JOB# _____

Project _____

AP # _____

Test Hole # _____

Elevation of Rim _____

Depth of Well _____

Date	Time	Depth to Water Surface	Total Rainfall (to date)*	Rainfall Past 24 hours*	Comments

*Data from NOAA's National Weather Service, <http://w2.weather.gov/climate/index.php?wfo=eka>

APPENDIX C – EXPECTED DAILY WASTEWATER FLOWS

Type of Establishment	Gallons/person/day (unless otherwise noted)
Apartments, multiple family (per resident).....	60
Bathhouses and swimming pools.....	10
Camps:	
Campground with central comfort stations.....	35
With flush toilets, no showers.....	25
Construction camps (semi-permanent).....	50
Day Camps (no meals served).....	15
Resort camps (night and day) with limited plumbing.....	50
Luxury camps.....	100
Cottages and small dwellings with seasonal occupancy.....	50
Country clubs (per resident member).....	100
Country Clubs (per non-resident member present).....	25
Dwellings:	
Boarding houses.....	50
Additional for non-resident boarders.....	10
Luxury residence and estates.....	150
Multiple family dwellings (apartments).....	60
Rooming houses.....	40
Single family dwellings (per bedroom, up to 3).....	150
Hospitals (per bed space).....	250+
Hotels with private baths (2 persons per room).....	60
Institutions other than hospitals (per bed space).....	125
Laundries, self service (gallons per customer).....	50
Mobile home parks (per space).....	250
Motels, with kitchen (per bed space).....	50
Motels, (per bed space).....	40
Picnic Parks (toilet wastes only, per person).....	5
Picnic Parks (bathhouses, showers, toilets).....	10
Restaurants (toilets and kitchen wastes per patron).....	10
Restaurants (kitchen wastes per meal served).....	3
Restaurants, additional for bars and cocktail lounges.....	2
Schools:	
Boarding.....	100
Day, without gyms, cafeterias, or showers.....	15
Day, with gyms, cafeterias, and showers.....	25
Day, with cafeteria, but without gyms or showers.....	20
Service stations (per vehicle served).....	10
Theaters, Movie (per seat or car space).....	5
Travel trailer parks without individual sewer hook-ups (per space).....	50
Travel trailer parks with individual water and sewer hook-ups (per space).....	100
Workers, day, at schools and offices (per shift).....	15
Stores (per toilet room).....	400
Factories (gallons per person, per shift, exclusive of industrial wastes).....	35

NOTES

1. A TYPICAL BACKHOE TEST PIT IS 24" WIDE, 5 TO 8 FEET DEEP. THE INTENT IS TO IDENTIFY ALL SOIL TYPES PRESENT TO A DEPTH NOT LESS THAN 3 FEET BELOW THE BOTTOM OF A LEACH LINE TRENCH.
2. SOIL TEXTURAL ANALYSIS AND PERCOLATION TESTING SHALL BE PERFORMED ON THE MOST RESTRICTIVE SOIL TYPE OBSERVED.
3. IF UNDERGROUND UTILITIES POTENTIALLY EXIST IN THE AREA OF EXCAVATION, CONTACT UNDERGROUND SERVICE ALERT AT 811 48 HOURS BEFORE DIGGING.
4. COMPLY WITH CAL-OSHA AND OTHER APPLICABLE FEDERAL, STATE, AND LOCAL REQUIREMENTS WHILE PERFORMING THE WORK.

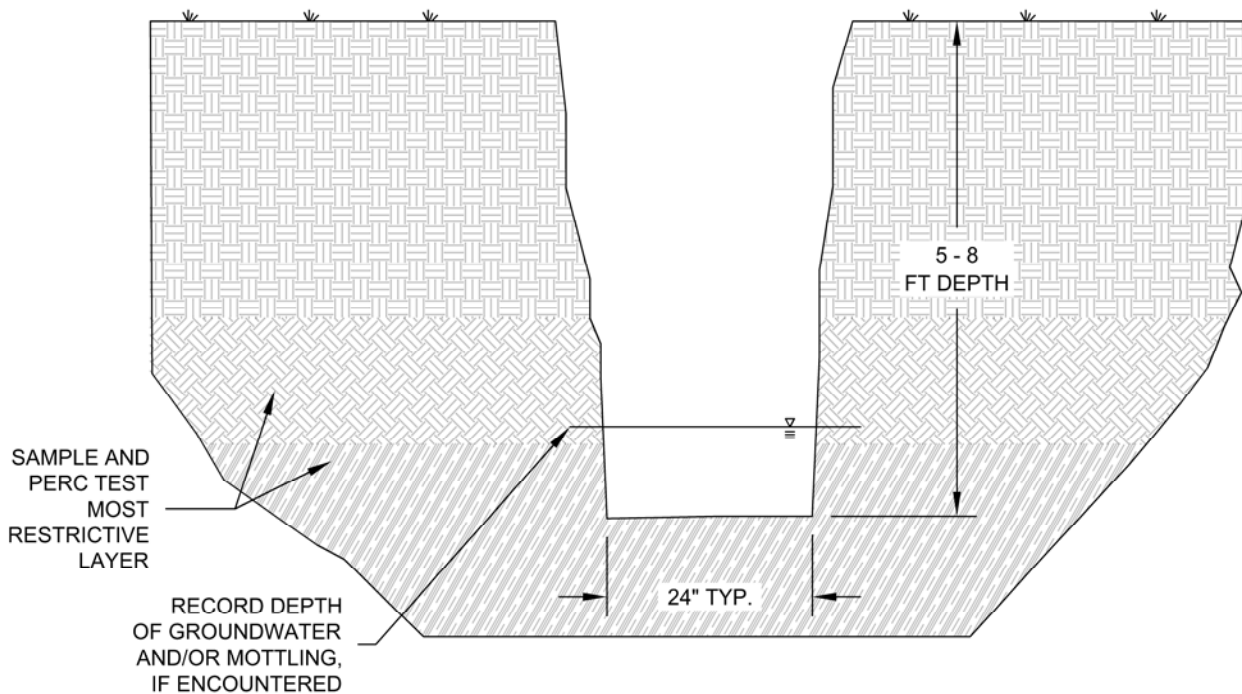

Percolation Rate(mpi)	Soil Application Rate gpd/ft ²	Zone 2 Soil Texture (when no percolation testing is performed)
5	0.732	
10	0.554	
15	0.481	Loamy Sand
20	0.425	
25	0.389	Sandy Loam
30	0.363	
35	0.344	Sandy Clay Loam
40	0.323	
45	0.305	Silt Loam
50	0.296	
55	0.285	
60	0.277	



COUNTY OF HUMBOLDT

DIVISION OF ENVIRONMENTAL HEALTH
LAND USE UNIT

100 H Street, Suite 100 EUREKA, CA 95501

TEL (707) 445-6215 * envhealth@co.humboldt.ca.us

TYPICAL BACKHOE TEST PIT

NOTES

1. WELL DEPTH MUST BE SUFFICIENT TO VERIFY APPROPRIATE GROUNDWATER SEPARATION FROM THE BOTTOM OF PROPOSED DISPERSAL FIELD TRENCHES.
2. EACH SITE SHALL HAVE A MINIMUM OF TWO WELLS TO DEMONSTRATE GROUNDWATER LEVELS IN THE PROPOSED PRIMARY AND RESERVE AREAS.
3. PROVIDE A COMPLETED "NOTIFICATION OF WET WEATHER MONITORING WELL INSTALLATION" FORM TO DEH WITHIN FIVE (5) DAYS OF WELL CONSTRUCTION.

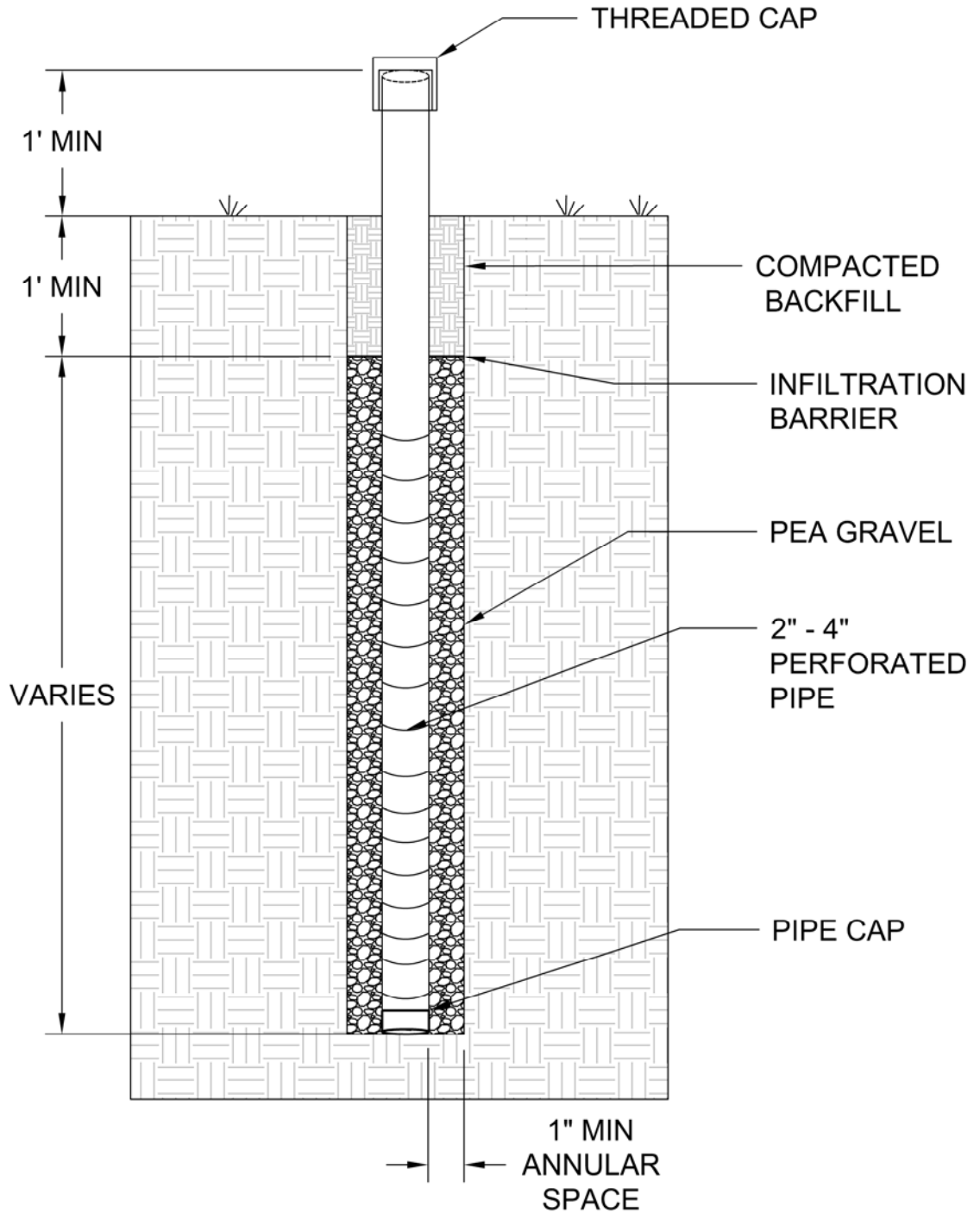

COUNTY OF HUMBOLDT

DIVISION OF ENVIRONMENTAL HEALTH
LAND USE UNIT

100 H Street, Suite 100 EUREKA, CA 95501
TEL (707) 445-6215 * envhealth@co.humboldt.ca.us

TYPICAL OBSERVATION WELL

NOTES

1. DETAILS SHOWN REPRESENT TYPICAL TRENCH CONFIGURATIONS. ACTUAL DIMENSIONS MAY VARY BASED ON SITE SOIL CONDITIONS.
2. MATERIALS SHALL BE AS SPECIFIED IN THE HUMBOLDT COUNTY OWTS REGULATIONS AND TECHNICAL MANUAL.
3. ALL SMEARED OR COMPACTED SOIL SURFACES IN THE SIDEWALLS OR BOTTOM OF TRENCHES SHALL BE SCARIFIED TO THE DEPTH OF THE SMEARING OR COMPACTION AND THE LOOSE MATERIAL REMOVED PRIOR TO PLACEMENT OF DRAIN ROCK.
4. LENGTH OF TRENCH IS BASED ON SOIL SAMPLING AND ANALYSIS. REFER TO THE HUMBOLDT COUNTY OWTS REGULATIONS AND TECHNICAL MANUAL.

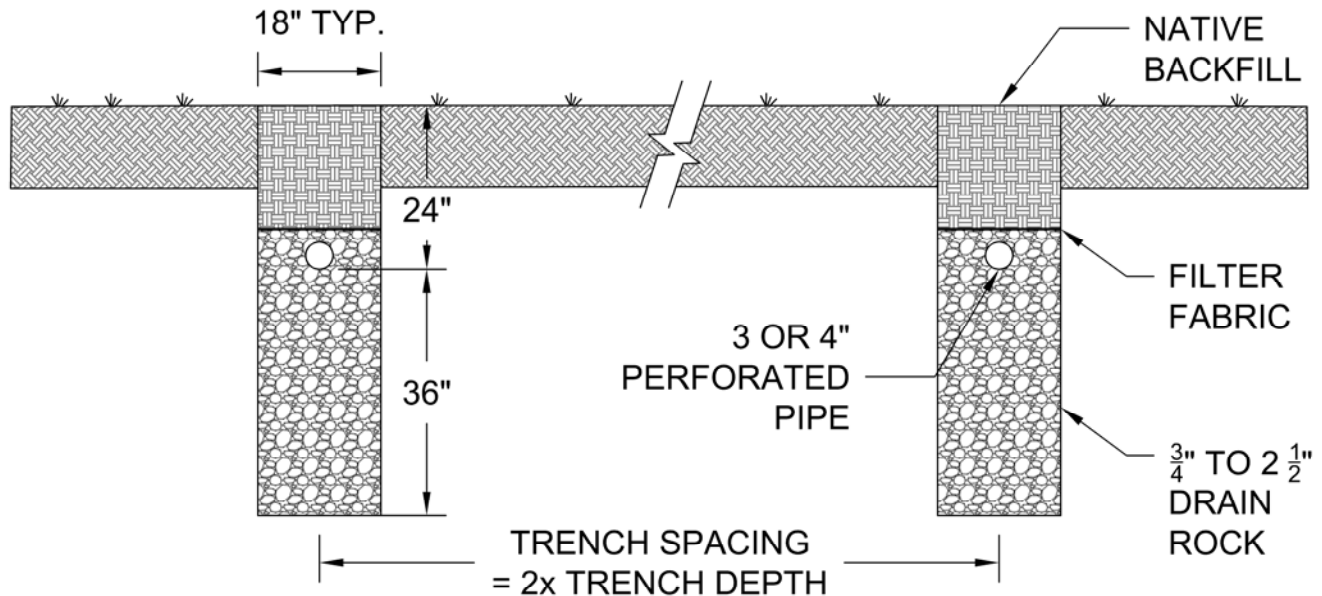

COUNTY OF HUMBOLDT

DIVISION OF ENVIRONMENTAL HEALTH
LAND USE UNIT

100 H Street, Suite 100 EUREKA, CA 95501
TEL (707) 445-6215 * envhealth@co.humboldt.ca.us

**DISPERSAL FIELD CONSTRUCTION
GRAVEL TRENCH**

NOTES

1. DETAILS SHOWN REPRESENT TYPICAL TRENCH CONFIGURATIONS. ACTUAL DIMENSIONS MAY VARY BASED ON SITE SOIL CONDITIONS.
2. MATERIALS SHALL BE AS SPECIFIED IN THE HUMBOLDT COUNTY OWTS REGULATIONS AND TECHNICAL MANUAL.
3. ALL SMEARED OR COMPACTED SOIL SURFACES ON THE BOTTOM OF TRENCHES SHALL BE SCARIFIED TO THE DEPTH OF THE SMEARING OR COMPACTION AND THE LOOSE MATERIAL REMOVED PRIOR TO PLACEMENT OF CHAMBERS.
4. LENGTH OF TRENCH IS BASED ON SOIL SAMPLING AND ANALYSIS. REFER TO THE HUMBOLDT COUNTY OWTS REGULATIONS AND TECHNICAL MANUAL.

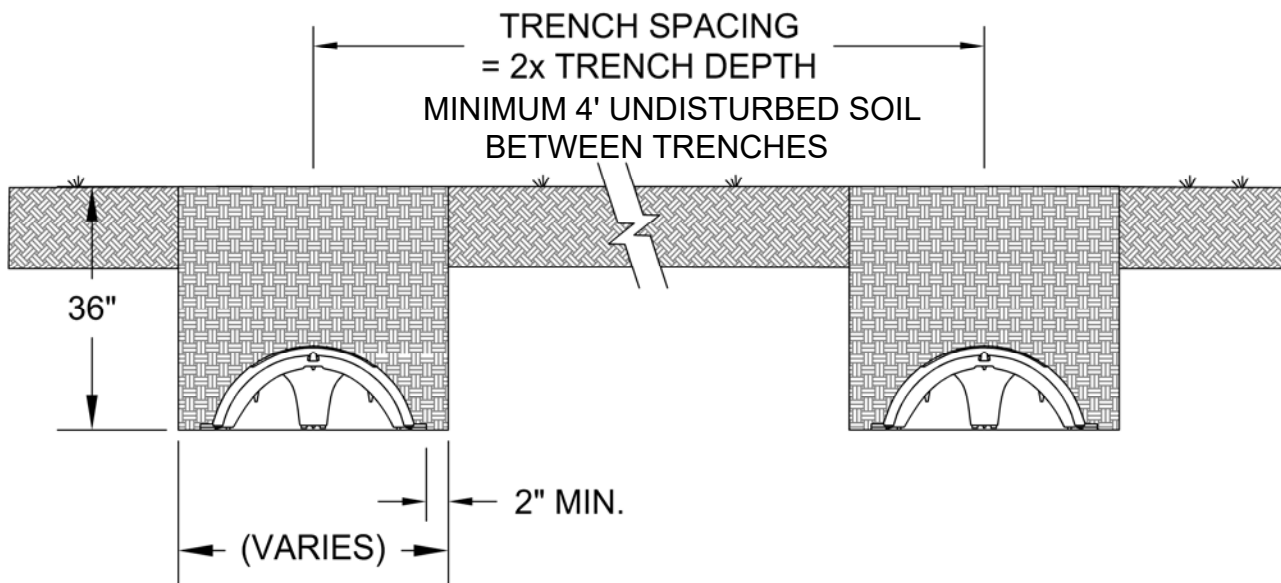
**COUNTY OF HUMBOLDT**

DIVISION OF ENVIRONMENTAL HEALTH
LAND USE UNIT

100 H Street, Suite 100 EUREKA, CA 95501
TEL (707) 445-6215 * envhealth@co.humboldt.ca.us

**DISPERSAL FIELD CONSTRUCTION
GRAVELLESS CHAMBERS**

APPENDIX E – OWTS SETBACK REQUIREMENTS

Minimum Setback Distance Requirements

Tanks and dispersal fields must be located to meet the minimum setback distances shown below. See page reverse for required OWTS horizontal setbacks to public water wells and surface water intakes.

Minimum Horizontal Distance (ft.)	Public Water Well	Private Water Well	Surface Intake Public Water	Perennial Stream, Wetland & Other Waters*	Ephemeral Stream or Drainage Swale*
Septic Tank	100	100		50	25
Pump Tank	100	100		50	25
Dispersal System	150	100	200-400 (see table below)	100	50

Minimum Horizontal Distance (ft.)	Property Lines Public Water	Property Lines (Private Water)	Buildings or Structures	Cut Banks Unstable Land Steep Slopes>30%	Large Trees
Septic Tank	5	25	5	25	10
Pump Tank	5	25	5	25	10
Dispersal System	10	50	10	25	10

* Setback distances from surface waters is determined based on the US Army Corps of Engineers' definition of Ordinary High Water Mark, 33 CFR 328.3(e).

APPENDIX E – OWTS SETBACK REQUIREMENTS

OWTS Horizontal Separation Distance to Public Water Wells & Surface Water Intake State OWTS Policy Section 9.4.10.1, .4, .5

	Public Water Well	Surface Water Intake
New OWTS	150 ft.	400 ft. from High Water mark of Water Body when: Dispersal system is within 1200 ft. of intake and, located within the catchment of the drainage such that it may impact the intake point.
New OWTS		200 ft. from High Water mark of Water Body when: Dispersal system is between 1200 ft. and 2500 ft. of intake and, located within the catchment of the drainage such that it may impact the intake point.
Replacement OWTS	150 ft.	400 ft. from High Water mark of Water Body when: Dispersal system is within 1200 ft. of intake and, located within the catchment of the drainage such that it may impact the intake point.
Replacement OWTS		200 ft. from High Water mark of Water Body when: Dispersal system is between 1200 ft. and 2500 ft. of intake and, located within the catchment of the drainage such that it may impact the intake point.

State OWTS Policy 9.4.11

For replacement OWTS that do not meet the above horizontal separation requirements, the replacement OWTS shall meet the horizontal separation to the greatest extent practicable. In such case, the replacement OWTS shall utilize supplemental treatment and other mitigation measures, unless the permitting authority finds that there is no indication that the previous system is adversely affecting the public water source, and there is limited potential that the replacement system could impact the water source based on topography, soil depth, soil texture and groundwater separation.

State OWTS Policy 9.4.12

For new OWTS installed on parcels of record existing as of May 13, 2013 that cannot meet the above horizontal separation requirements, the OWTS shall meet the horizontal separation to the greatest extent practicable and shall utilize supplemental treatment for pathogens as specified in section 10.8 (State OWTS Policy) and any other measures prescribed by the permitting authority.

APPENDIX F
POLICY FOR THE USE OF
EXISTING ONSITE WASTEWATER TREATMENT SYSTEMS (OWTS)

The use of an existing OWTS to serve a structure remodel, replacement, or change of use, will be acceptable if the OWTS is functioning properly, is sized appropriately for the proposed project, and the project does not impact the designated OWTS replacement area. Remodeling, replacement, or a planned change in use which will not affect the daily flow to the OWTS, and will not impact the remaining potential replacement area, will not require expansion, testing, or replacement of the existing OWTS.

The acceptability of an existing OWTS for new construction, remodeling, or change in use will be determined as follows:

1. Existing OWTS which were approved by the Division of Environmental Health (DEH) after January 1, 1980, for which soils testing in accordance with the North Coast Regional Water Quality Control Board "Basin Plan Policy" has been conducted, will be acceptable for use without further testing if: (1) the system shows no sign of failure or damage; and (2) the proposed development is compatible with the system as installed; and (3) the proposed development does not impact available OWTS replacement area.
2. Existing OWTS installed prior to January 1, 1980 will be evaluated for approval as follows:
 - a. Applicants may be requested to expose portions of an existing OWTS to verify its size and location where no record or inadequate record of the OWTS exists. Soil testing in conformance with the Humboldt County Onsite Wastewater Treatment System Regulations & Technical Manual (RTM) will be required in the primary and replacement area(s) to determine if the existing OWTS is sized appropriately for the intended use and that adequate replacement area exists. Expansion of an existing OWTS must be accomplished in accordance with the RTM.
 - b. Existing OWTS which are functioning properly and are of the appropriate size will be accepted for use if soil testing demonstrates suitability. Expansion of a system must be accomplished in accordance with the RTM.

The provisions of this policy may be waived, on a case-by-case basis, by the Department of Health and Human Services, Division of Environmental Health Director where extreme hardship, such as a dwelling destroyed by a fire, can be demonstrated.

This Policy was approved by the Humboldt County Board of Supervisors on _____.

(Prior version entitled "Policy for the Use of Existing Sewage Disposal Systems" was implemented on October 23, 1984.)

APPENDIX G

Graywater Regulations

Introduction

Humboldt County Division of Environmental Health (DEH) issues permits for graywater treatment systems. These regulations provide criteria for permitting and design of these systems for new construction and for modifications of existing wastewater treatment systems.

Reference Standards

Graywater systems shall be designed, constructed, and operated in accordance with the 2016 California Plumbing Code (CPC) Chapter 15, Section 1502. DEH is the Enforcing Agency, and the Authority Having Jurisdiction for all components of the graywater treatment system outside of the building footprint. Modifications to interior plumbing systems are the jurisdiction of the Humboldt County Building Division.

A graywater system is not a replacement for an Onsite Wastewater Treatment System (OWTS). Graywater systems do not reduce the size of an OWTS, and all graywater must be able to be redirected to an approved OWTS or public sewer.

Permitting

Graywater systems are permitted using the DEH Onsite Wastewater Treatment System (OWTS) Permit Application. Clothes washer systems in compliance with 2016 CPC Section 1502.1.1 are exempt from OWTS permit. All other graywater systems require an OWTS permit. All graywater OWTS permit applications must be accompanied by a building permit application for the required internal plumbing modifications.

1. Graywater OWTS permit applications shall be submitted through the Humboldt County Building Division simultaneously with submittal of the building permit application.
2. Graywater OWTS permit applications must include a design submittal, per Section 2.6 of the Humboldt County Onsite Wastewater Treatment System (OWTS) Regulations and Technical Manual, and the appropriate fee.
3. DEH inspector may perform a pre-site inspection to verify the conditions described in the design report. If the application is complete and the design acceptable, the permit application will be approved for construction and DEH-approved plans will be provided to the applicant. DEH reserves the right to make any and all modifications to the proposed design that may be necessary to meet these regulations and/or the CPC.
4. The applicant must notify the DEH inspector a minimum of 48 hours prior to the construction of the gray water system. During construction, the DEH inspector will make a site visit to verify that the construction is consistent with the DEH approved design. Deviation from the approved design may require correction at the discretion of the inspector. If the construction is acceptable, the DEH inspector will finalize the OWTS permit and approve the construction. The Building Division retains authority for interior plumbing and other building construction permit approvals.

Appendix H – Variance Prohibition Areas

Section 9.1 Conditions/Characteristics	Geographic Area/Hydrologic Unit (HU) Tier 1 Requirements Infeasible	Mitigation Measures that may be Considered (Wet Weather Testing in All Areas)	
		New System (No Variance)	Repair
9.1.1 Degree of Vulnerability due to Hydrogeological conditions.	Westhaven, Fieldbrook, Fairhaven, Eureka Plain HU, Van Duzen River HU	NSOWTS, Supplemental Treatment	NSOWTS, Supplemental Treatment
9.1.2 High Quality Waters/Environmental Conditions requiring enhanced protection	Trinidad HU, Eureka Plain HU, Fairhaven, Van Duzen River HU	Supplemental Treatment	Supplemental Treatment
9.1.3 Shallow Soils	Westhaven, Fieldbrook, Eureka Plain HU	NSOWTS - Mound, Supplemental Treatment	NSOWTS - Mound, Supplemental Treatment
9.1.4 OWTS in area of high domestic well usage	Van Duzen River HU, Alton, Petrolia	Supplemental Treatment & Disinfection	Supplemental Treatment & Disinfection
9.1.5 OWTS in area of fractured rock	Benbow, Shelter Cove	NSOWTS, Supplemental Treatment	NSOWTS, Supplemental Treatment
9.1.6 OWTS in area of poorly drained soils	Fieldbrook, Eureka Plain HU, Petrolia	NSOWTS - Mound	NSOWTS - Mound, Supplemental Treatment
9.1.7 Surface Water vulnerable to pollution from OWTS	Trinidad HU, Eureka Plain HU, Fairhaven, Van Duzen River HU	NSOWTS, Supplemental Treatment	NSOWTS, Supplemental Treatment
9.1.8 OWTS within Tier 3 area	Trinidad HU, Clam Beach	NSOWTS, Supplemental Treatment, APMP Special Provisions	APMP Special Provisions
9.1.9 Area of high OWTS density	Pacific Manor subdivision, Fairhaven, Van Duzen River HU	NSOWTS, Supplemental Treatment, Cumulative Impact Study, Water Efficient Fixtures	
9.1.10 Parcel size susceptible to hydraulic mounding, nitrogen loading	Fairhaven, Pacific Manor subdivision, Petrolia, Hydesville,	NSOWTS, Supplemental Treatment	NSOWTS, Supplemental Treatment
9.1.11 Multiple OWTS predating standards	Alton, Petrolia, Fairhaven, Westhaven		Conformance with RTM
9.1.12 OWTS located within pertinent setbacks	Alton	NSOWTS, Supplemental Treatment & Disinfection	NSOWTS, Supplemental Treatment & Disinfection

Trinidad HU covers the area from Big Lagoon south to Little River.

Eureka Plain HU includes Jacoby Creek, Bayside, Freshwater, Elk River.

Van Duzen River HU covers the area from Bridgeville west to Hydesville.

The table above lists the primary areas in Humboldt County where conditions listed in 9.1.1 – 9.1.12 occur and prevent the use of Tier 1 siting criteria for the design and installation of an OWTS.

Appendix 2: Humboldt County Code, Title VI, Divisions 1 and 2

TITLE VI - WATER AND SEWAGE

DIVISION 1

SEWAGE AND ONSITE WASTEWATER TREATMENT DISPOSAL

Chapter 1 - General Requirements

- § 611-1. Purpose.
- § 611-2. Definitions.
- § 611-3. Approved Sewage ~~Disposal~~ Treatment System Required.
- § 611-4. Sewer Connection Required.
- § 611-5. Maintenance.
- § 611-6. Abandoned ~~Sewage Disposal~~ Onsite Wastewater Treatment Systems.
- § 611-11. Lot Inspections.
- § 611-12. Subdivisions.

Chapter 2 - Regulations and Administration

- § 612-1. Regulations.
- § 612-2. Permits.
- ~~§ 612-3. Lapse of Existing Permits.~~
- § 612-~~4~~3. Appeals.
- § 612-~~5~~4. Investigation and Abatements.
- § 612-~~6~~5. Declaration of Public Nuisance.
- § 612-~~7~~6. Penalty.
- § 612-~~8~~7. Responsibility for Damage.

Chapter 3 - Prohibitions

- § 613-1. General Prohibitions.
- § 613-2. Cesspools and Waste Wells Prohibited.
- § 613-3. ~~Bored Pits and Seepage Pits~~ Prohibited.
- § 613-4. Privies Prohibition of Holding Tanks; Portable Toilets; Vault Toilets.
- § 613-5. Pit Privies.

Chapter 4 - Moratoria

- § 614-1. Moratoria.

Chapter 5 - Experimental Disposal System Program

- § 615-1. Purpose.
- § 615-2. General Requirements.
- § 615-3. Applicants' Qualifications.
- § 615-4. Permits.
- § 615-5. Information Sharing.
- § 615-6. Waterless Toilet Systems.
- ~~§ 615-7. Greywater Disposal Systems.~~
- § 615-~~8~~7. Prototype Experimental Systems.
- § 615-~~9~~8. Inspections.

**Chapter 6 - Maintenance Oversight of Non-Standard ~~Water-Carried Sewage Disposal~~
Onsite Wastewater Treatment Systems**

- § 616-1. Intent.
- § 616-2. Definitions.
- § 616-3. Operational Permit Required for Non-Standard Systems.
- § 616-4. Revocation.
- § 616-5. Abatement.
- § 616-6. Provisions Cumulative.

Chapter 7 - Graywater Systems.

- § 617-1. Design, Construction, and Permitting.

TITLE VI - WATER AND SEWAGE

DIVISION 1

SEWAGE DISPOSAL AND ONSIDE WASTEWATER TREATMENT

CHAPTER 1

GENERAL REQUIREMENTS

611-1. PURPOSE AND FINDINGS.

~~This division shall apply to all territory embraced within the unincorporated area of the County of Humboldt, State of California. The Board of Supervisors finds that the growth and development of the County have given rise to undesirable alterations of the ecology of the County and increasing problems of sewage disposal detrimental to the continued health, safety and well-being of the inhabitants of this County. It is basic that means of preventing ecologic strain and of resolving problems of sewage disposal must be provided. The Board of Supervisors enacts this division for the control of individual sewage disposal systems in the County in order to promote the health, safety and well-being of the inhabitants of this County by providing to them a means to prevent ecologic strain and resolve problems of sewage disposal.~~

~~To implement and ensure this goal, t~~The Board of Supervisors finds that in urban areas of the County the most appropriate means of sewage disposal treatment is the public sewer system. The Board further finds that, in the rural lands of the County, the dispersal or leach field method of sewage disposal treatment is the most appropriate means of sewage disposal treatment and is to be considered a permanent means. (Ord. 945, § 1, 10/2/73; Ord. _____, § __, __/2017)

The Board of Supervisors enacts this division for the management of sewage treatment systems in the County in order to promote the health, safety, and well-being of the inhabitants of this County by providing to them a means to prevent water pollution, nuisances, and threats to public health. (Ord. _____, § __, __/2017)

In addition, this division is intended to bring Humboldt County into compliance with the Water Quality Control Policy for Siting, Design, Operation, and Maintenance of Onsite Wastewater Treatment Systems and applicable policies and regulations of the State Water Resources Control Board. (Ord. _____, § __, __/2017)

This division shall apply to all territory embraced within the unincorporated area of the County of Humboldt, State of California. (Ord. _____, § __, __/2017)

611-2. DEFINITIONS.

(a) Abandoned Onsite Wastewater Treatment Sewage Disposal System. "Abandoned onsite wastewater treatment sewage disposal system" means an onsite wastewater treatment a sewage disposal system of which use has been discontinued with the intent of never resuming such use. Nonuse of such a sewage disposal system for a period of one (1) year shall be prima facie proof of such intent. (Ord. _____, § __, __/2017)

(b) Building and Place. "Building" or "place" means any residence, place of business, or other building or place where persons reside, congregate, or are employed. (Ord. _____, § __, __/ /2017)

(c) Cesspool. "Cesspool" means an excavation in the ground receiving domestic wastewater, designed to retain the organic matter and solids, while allowing the liquids to seep into the soil. Cesspools do not have septic tanks. a covered pit with open jointed lining into which sewage or waste is discharged, the liquid portion of which is disposed of by leaching into the surrounding soil and the solids or sludge being retained in the pit. (Ord. _____, § __, __/ /2017)

(d) Dispersal System. "Dispersal system" means a leachfield, mound, at-grade, subsurface drip field or other type of system for final wastewater treatment and subsurface discharge. (Ord. _____, § __, __/ /2017)

(e) Graywater. "Graywater" means untreated wastewater that has not been contaminated by any toilet discharge; has not been affected by infectious, contaminated, or unhealthy bodily wastes; and does not present a threat from contamination by unhealthful processing, manufacturing, or operating wastes. "Graywater" includes wastewater from bathtubs, showers, bathroom washbasins, clothes washing machines, and laundry tubs, but does not include wastewater from kitchen sinks or dishwashers. Graywater as defined above has the same meaning as "gray water," "grey water," and/or "greywater." (Ord. _____, § __, __/ /2017)

(f) Grease Interceptor. "Grease interceptor" means a plumbing appurtenance or appliance that is installed in a sanitary drainage system to intercept non-petroleum fats, oils, and greases (FOG) from a wastewater discharge. (Ord. _____, § __, __/ /2017)

(dg) Health Officer. "Health Officer" means the Humboldt County Health Officer or his/her authorized representative or designee. (Ord. _____, § __, __/ /2017)

(h) Onsite Wastewater Treatment System or OWTS. "Onsite wastewater treatment system(s)" or "OWTS" means a water-carried system for the sanitary, safe, and nuisance-free receipt and treatment of sewage and wastewater. OWTS may also be referred to or known as a septic system, sewage treatment system, or sewage disposal system. The short form of the term may be singular or plural. (Ord. _____, § __, __/ /2017)

(I) Onsite Wastewater Treatment System Failure or OWTS Failure. "Onsite wastewater treatment system failure" or "OWTS failure" includes, but is not limited to, the following: (Ord. _____, § __, __/ /2017)

(1) Surfacing of effluent with the bacteriological or chemical characteristics of sewage. (Ord. _____, § __, __/ /2017)

(2) Sluggish or inoperative plumbing fixtures. (Ord. _____, § __, __/ /2017)

(3) The flow or seepage of effluent from an onsite wastewater treatment system into surface or subsurface waters. (Ord. _____, § __, __/ /2017)

~~(e) Privy. "Privy" means a device for the disposal of sewage in a pit in the earth which may be covered by a structure.~~

(j) Pit Privy. "Pit privy" means a self-contained waterless toilet used for disposal of non-water carried human waste; consists of a shelter built above a pit in the ground into which human waste falls. Also known as an outhouse or pit-toilet. (Ord. _____, § __, __/ /2017)

(fk) Public Nuisance. "Public Nuisance" means anything which:

(1) Is injurious to health or well-being, or is indecent or offensive to the senses, or is an obstruction to the free use of the land space, or interferes with the comfortable enjoyment of life or environment; or and (Ord. _____, § __, __/ /2017)

(2) Affects at the same time the occupants of one (1) or more habitable units of a community or neighborhood, or any considerable number of persons, although the extent of the annoyance, damage, injury, offense, obstruction or interference inflicted upon individuals may be unequal; or (Ord. _____, § __, __/ /2017)

(3) Any condition, action, or use defined in § 351-3. (Ord. _____, § __, __/ /2017)

(gl) Public Sewer. "Public Ssewer" means a common sewer system operated by a public entity. (Ord. _____, § __, __/ /2017)

(hm) Public Water System. "Public water system" means ~~any a water system for which a permit is required by the State of California or by the County of Humboldt pursuant to the Pure Water Act (Health and Safety Code §§ 4010 et seq.) regulated by the State Water Resources Control Board or a Local Primacy Agency pursuant to the California Safe Drinking Water Act, Chapter 12, Part 4, Section 116275(h) of the California Health and Safety Code.~~ (Ord. _____, § __, __/ /2017)

(n) Qualified Professional. "Qualified Professional" means a Registered Civil Engineer, Registered Environmental Health Specialist, Professional Geologist, or Certified Soil Scientist who has experience designating standard or non-standard onsite wastewater treatment systems. (Ord. _____, § __, __/ /2017)

(to) Repair. "Repair" means any alteration ~~of and/or~~ replacement of any dispersal system component or tank of an onsite wastewater treatment system as a result of system failure of a sewage disposal system. (Ord. _____, § __, __/ /2017)

(p) Seepage Pit. "Seepage pit" means a drilled or dug excavation, three to six feet in diameter, which receives the effluent discharge from a septic tank or other OWTS treatment unit for dispersal. (Ord. _____, § __, __/ /2017)

(g) Septic Tank. "Septic tank" means a watertight, covered receptacle designed for primary treatment of wastewater and constructed to: (Ord. _____, § __, __/ /2017)

- (1) Receive wastewater discharged from a building; and
- (2) Separate settleable and floating solids from the liquid; and
- (3) Digest organic matter by anaerobic bacterial action; and
- (4) Store digested solids; and
- (5) Clarify wastewater for further treatment with final subsurface discharge.

(jr) Sewage. "Sewage" means any substance, liquid or solid, which is classified as a waste product of human habitation occupation and may be injurious or dangerous to health, and which contains or may be contaminated with human or animal excrement, offal, or feculent matter. Sewage may be synonymous with "wastewater" and/or "liquid waste". (Ord. _____, § __, __/ /2017)

~~(k) Sewage Disposal System. "Sewage disposal system" means a system for the sanitary, safe and nuisance-free disposal of sewage or waste other than a public sewer.~~

~~(l) Sewage Disposal System Failure. "Sewage disposal system failure" includes but is not limited to the observation by the Health Officer of any of the following:~~

~~_____ (1) Surfacing of effluent with the bacteriological or chemical characteristics or sewage.~~

~~_____ (2) Sluggish or inoperative plumbing fixtures.~~

~~_____ (3) The flow or seepage of effluent into surface or subsurface waters by effluent from a sewage disposal system.~~

(s) Sewage Treatment System. "Sewage treatment system" means a system for the sanitary, safe, and nuisance-free receipt and treatment of sewage or waste other than a public sewer. (Ord. _____, § __, __/ /2017)

~~(m) Vault Privy. "Vault privy" means a water-tight, underground tank for the temporary storage of sewage or waste.~~

(t) Vault. "Vault" means an enclosed receptacle for the receipt and temporary storage of wastewater, such as, but not limited to, grease interceptors, grease traps, chemical toilets, vault toilets, and holding tanks. (Ord. _____, § __, __/ /2017)

(mu) Waste. "Waste" means any and all waste substances, liquid, solid or gaseous, associated with any producing, manufacturing, processing or commercial operation, of whatever nature, which substances are not further used by the entity association producing, manufacturing, processing or commercial operation. (Ord. _____, § __, __/ /2017)

(ov) Waste Well. "Waste well" means any hole in the ground used or intended to be used for the disposal of sewage, liquid or waste, or wastewater. (Ord. 945, § 2, 10/2/73; Ord. _____, § __, __/ /2017)

611-3. APPROVED SEWAGE DISPOSAL TREATMENT SYSTEM REQUIRED.

No person shall construct, reconstruct, repair, maintain, or use or occupy any building or place which is not provided with a sewage disposal treatment system approved by the Health Officer or provided with a connection to a public sewer. (Ord. 945, § 3, 10/2/73; Ord. _____, § __, __/ /2017)

611-4. SEWER CONNECTION REQUIRED.

(a) Connection Required. Every building or place which is within 300 feet of an approved public sewer shall be connected to the public sewer by the owner in accordance with and subject to requirements and/or conditions set forth by the public sewer authority, or his agent. A separate connection for each building or place may be required. The measurement of the 300 feet shall start at a point where the public sewer authority's jurisdiction terminates and continue be as follows: starting to the point where the permitting agency's jurisdiction ends (property line or curb line) to the nearest point of the property. The location of a structure upon the property shall not be a contributing factor unless the structure is located more than 1,000 feet from the public sewer line. (Ord. _____, § __, __/ /2017)

(b) Large Flow Situations. Multiple family units, mobilehome park, commercial establishments, motels, hotels, subdivision and minor subdivisions, and other buildings or places creating a large flow of sewage or waste may be required by the Health Officer to connect from distances greater than 300 feet. In requiring connections from greater distances, the Health Officer shall consider for the long term the following:

- (1) The intent and purpose of this division.
- (2) Effect on the General Plan, the Zoning Title and the Open Space Plan.
- (3) Potential nuisance creation.
- (4) Quantity of sewage flow.
- (5) Cost and suitability of such connection relative to the cost and suitability of constructing and maintaining sewage ~~disposal~~ treatment systems. (Ord. _____, § __, __/2017)
- (6) Such other factors as the Health Officer deems appropriate.

(c) Failed Systems. In instances of an onsite wastewater treatment system serious sewage system failure as defined in § 611-2(I), where site conditions preclude the installation of a reliable onsite wastewater treatment system replacement, the Health Officer may require connection to an approved public sewer from a distance of up to 1,000 feet. (Ord. _____, § __, __/2017)

(d) Pump Required. In the event a person required by this section to connect to a public sewer ~~line~~ does not have gravity flow to the public sewer ~~line~~, he/she shall be required to install and maintain a sump pump at his/her own expense at the time of the hookup. Such installation shall be subject to the regulations of the ~~public~~ entity operating the public sewer. (Ord. _____, § __, __/2017)

(e) Easements. This Board will assist any individual required under this section to connect to a public sewer in attempting to acquire any easements which may be necessary to allow for the most direct connection to the public sewer ~~line~~. (Ord. _____, § __, __/2017)

(f) Permit Procedures. Permit procedures, inspection procedures; and materials related to connection to a public sewer shall be in accordance with the specifications of the public entity operating the public sewer.

(g) Connection to Public Sewers. All points of wastewater discharge from the building or place subject to which fall under the provisions of this section shall be connected to the public sewer line. ~~No sewage disposal system shall be connected to any public sewer.~~ (Ord. _____, § __, __/2017)

(h) ~~Alternative System Permits.~~ Waterless Toilet Permits. Notwithstanding the above, the Health Officer may permit the installation and use of waterless toilets ~~and greywater disposal systems approved for participation in the Department of Health Services - State Water Resources Control Board Research Project as described in Chapter 5 of this division.~~ (Ord. 945, § 4, 10/2/73; Ord. 1275, § 1, 9/12/78; Ord. 1338, § 1, 7/10/79; Ord. _____, § __, __/2017)

611-5. MAINTENANCE OF ONSITE WASTEWATER TREATMENT SYSTEMS.

(a) ~~The operator owner of a dual-field installation shall alternate the field at times specified by the Health Officer~~ an onsite wastewater treatment system shall comply with the operational and maintenance requirements specified on the approved permit application. In addition, the owner of a non-standard onsite wastewater treatment system shall comply with Chapter 6 of this division. (Ord. _____, § __, __/2017)

(b) The operator of a dual-field dispersal system shall alternate the field annually or at times specified by the Health Officer. (Ord. _____, § __, __/__/2017)

(bc) Unless otherwise specified by the Health Officer, septic tanks shall be pumped at least once every seven (7) years. (Ord. 945, § 7, 10/2/73; Ord. _____, § __, __/__/2017)

611-6. ABANDONED ONSITE WASTEWATER TREATMENT ~~SEWAGE DISPOSAL~~ SYSTEMS.

(a) Every abandoned building sewer or part thereof shall be plugged or capped in an approved manner within five feet (5') of the property line.

(b) Every abandoned septic tank shall have the sewage removed therefrom and be completely filled with earth, sand, gravel, concrete or other approved material. The cover of the septic tank shall be removed before filling. The filling shall not extend above the top of the vertical portions of the sidewalls or above the level of any outlet pipe until an inspection has been completed by the Health Officer. After such inspection by the Health Officer, the septic tank shall be filled to the level of the top of the ground. (Ord. _____, § __, __/__/2017)

(c) No person owning or controlling any septic tank shall fail, refuse, or neglect to comply with the provisions of this section upon receipt of notice from the Health Officer.

(d) Where an onsite wastewater treatment ~~a sewage disposal~~ system is abandoned consequent to connecting with the public sewer, the permittee property owner or his/her authorized representative making the connection shall fill the abandoned septic tank as required by the Health Officer within thirty (30) days from the time of connecting with the public sewer. (Ord. 945, § 10, 10/2/73; Ord. _____, § __, __/__/2017)

611-11. LOT INSPECTIONS SITE EVALUATIONS.

(a) ~~Upon request the Department of Health and Human Services Health Department Branch may make inspection of a lot and review available departmental records to determine the probable~~ The Health Officer may make inspection of a site to determine the potential suitability of the property for an onsite wastewater treatment system or to verify site evaluation information submitted by a Qualified Professional. ~~individual sewage disposal. The Health Officer may require that he/she be present along with the Qualified Professional conducting a site evaluation.~~ The Health Officer shall issue a report on the inspection findings to the property owner or his/her authorized representative. ~~A lot inspection~~ The report shall not constitute approval for the issuance of the onsite wastewater treatment system sewage disposal permit or a guarantee of such issuance. (Ord. 2351, § 18, 12/06/2005; Ord. _____, § __, __/__/2017)

(b) Each application for inspection of a lot site shall be accompanied by a fee set by resolution or ordinance of the Board of Supervisors in an amount sufficient to cover costs. When inspection of more than one lot site is requested, the fee shall be charged for each lot site. (Ord. 945, § 15, 10/2/73; Ord. 2351, § 18, 12/06/2005; Ord. _____, § __, __/__/2017)

611-12. SUBDIVISIONS AND LOT LINE ADJUSTMENTS.

(a) For any proposed subdivision or ~~minor subdivision~~ applicable lot line adjustment which will not be connected to a public sewer ~~system prior to sale of the lots~~, the Health Officer shall require site specific onsite wastewater treatment system designs for each proposed parcel before recommendations are presented to detailed plans of the means of sewage disposal to be used in the subdivision before presenting recommendations to the Planning Commission. The onsite system design for each proposed parcel shall be prepared from a site evaluation conducted by a Qualified Professional as defined in § 611-2(n). (Ord. _____, § __, __/__/2017)

(b) Such plans designs shall recognize that the ~~sewage disposal onsite wastewater treatment~~ demands of any particular subdivision cannot be analyzed without reference to the ~~sewage disposal onsite wastewater treatment~~ demands of the land surrounding the subdivision. (Ord. _____, § __, __/2017)

(c) Such plans designs shall recognize that the proposed ~~sewage disposal onsite wastewater treatment~~ systems of the subdivision must be viewed as a single system for purposes of analysis. The Health Officer may require that a cumulative impact study of the effects of wastewater discharge be conducted. (Ord. _____, § __, __/2017)

(d) Such plans designs shall be consistent with all the provisions of this division and regulations issued by the Health Officer. (Ord. _____, § __, __/2017)

(e) Such plans designs shall include provisions to meet sewage ~~disposal treatment~~ demands over the long term. (Ord. _____, § __, __/2017)

(f) Such plans designs shall require the approval of the Health Officer. Ord. _____, § __, __/2017

(g) The plans designs shall be accompanied by a fee ~~sufficient estimate~~ to cover the expenses incurred by the County in reviewing the plans designs. The fee shall be set by resolution or ordinance of the Board of Supervisors. In the event that the actual costs are less than the fee deposited, the balance shall be returned. In the event the actual costs are greater than the fee deposited, the subdivider shall pay to the County the excess of the actual costs over the amount of the fee deposited. (Ord. 945, § 16, 10/2/73; Ord. 2351, § 14, 12/06/2005; Ord. _____, § __, __/2017)

CHAPTER 2

REGULATIONS AND ADMINISTRATION

612-1. REGULATIONS.

(a) The Health Officer shall issue such regulations as he/she deems necessary to carry out the provisions of this division.

(b) Any such regulations issued by the Health Officer shall:

(1) Comply with current State laws, regulations, and policies.
(Ord. _____, § __, __/2017)

(~~1~~2) Be consistent with the intent and purpose of this division.
(Ord. _____, § __, __/2017)

(~~2~~3) Recognize the most current technical information relevant to the provisions of this division. (Ord. _____, § __, __/2017)

(~~3~~4) Provide for exceptions where a strict application of this division or local regulations issued by the Health Officer would inflict a substantial personal hardship upon the occupants of the building or place in question. (Ord. _____, § __, __/2017)

(~~4~~5) Be designed to minimize and eliminate public nuisance hazards or the potential thereof. (Ord. _____, § __, __/2017)

(~~5~~6) Recognize that any ~~single sewage disposal~~ single onsite wastewater treatment system is in reality a subunit of a larger ~~sewage disposal~~ wastewater treatment system comprised of numerous subunits. (Ord. _____, § __, __/2017)

(c) Regulations issued by the Health Officer under this division shall become effective when filed with the County Clerk.

(d) Regulations issued under this division may be amended by the Health Officer from time to time by filing such amendments with the County Clerk; amendments shall become effective when filed.

(e) Regulations issued under this division shall be available to the public on-line free of charge or in booklet form at for a fee to be determined by the Board of Supervisors. (Ord. 945, § 18, 10/2/73; Ord. _____, § __, __/2017)

612-2. PERMITS.

(a) Permit Required. No person shall construct, ~~reconstruct~~ modify, repair, replace, ~~maintain~~, abandon, ~~operate~~ or excavate for any kind of ~~sewage disposal onsite wastewater treatment~~ system or any portion thereof without having first obtained a permit to do so from the Health Officer. (Ord. _____, § __, __/2017)

~~(b) Exemptions. Connections to approved public sewers are exempted from the above permit requirement.~~

~~(c)~~ Applications.

(1) Each application for a permit to construct, ~~a sewage disposal~~ modify, repair, replace, abandon, or excavate for any kind of onsite wastewater treatment system ~~shall is to~~ be made on a form provided by the Health Officer.

(2) A separate application is required for each onsite wastewater system proposed. In cases where multiple OWTS are proposed for the same parcel, a separate application is required for each. (Ord. _____, § __, __/ /2017)

(23) The information which the applicant is required to present includes, but is not limited, to the following information: (Ord. _____, § __, __/ /2017)

A. Name, address and telephone number(s) of the applicant and the owner of the property, and their agents, if any, on which the building or place to be served by the ~~sewage disposal onsite wastewater treatment~~ system is located ~~and their agents if any.~~ (Ord. _____, § __, __/ /2017)

B. Location of the property, and the Assessor's parcel number, directions to the site, and any site accessibility restrictions. (Ord. _____, § __, __/ /2017)

C. A scale map of the lot showing: appropriate landmarks; steep slopes; roads; surveyor's landmarks; lot dimensions; existing and proposed easements for road or utility purposes; wells, waterbodies or drainage swales; and existing, proposed, or abandoned ~~sewage disposal onsite wastewater treatment~~ systems. (Ord. _____, § __, __/ /2017)

D. ~~Gross lot area, net lot area and average cross-slope of the lot.~~ A scaled site plan or detail of the proposed project showing the area of the work, the average cross slope, the structure(s) served, and all items in C (above) within one hundred fifty feet (150') of the project. (Ord. _____, § __, __/ /2017)

E. The intended use or uses of the property.

F. The number of dwelling units and rooms usable as sleeping quarters. If a nonresidential use is proposed, an estimate of the quantity of sewage flow and the method of estimating the flow shall be provided.

G. ~~The level of the ground water table during and at the end of the rainy season.~~ Soils testing information from a site evaluation performed by a Qualified Professional, including wet weather ground water elevations and percolation test results as required by the regulations issued by the Health Officer, as referenced in § 612-1(a). (Ord. _____, § __, __/ /2017)

H. The source or purveyor of domestic water.

I. Plans and specifications for the proposed ~~sewage disposal onsite wastewater treatment~~ system showing ~~to scale the location of the proposed system to all structures, wells and water courses, property lines, reserve areas, and any other information as specified by the regulations issued by the Health Officer may deem necessary.~~ (Ord. _____, § __, __/ /2017)

~~J. A statement from the Humboldt County Planning Department that the proposed development of the site is consistent with the General Plan, the Zoning Title and the Open Space Conservation Plan, and an opinion on whether the proposed development may exert pressures which will detrimentally affect the implementation of the General Plan, the Zoning Title or the Open Space Conservation Plan.~~

~~K. Soil characteristics.~~

~~HJ.~~ Other information which the Health Officer may deem to be necessary to the making of an informed and professional decision on the application. (Ord. _____, § __, __/2017)

~~(3) The Health Officer may require that analysis of soil characteristics or of the percolative capacity of the soil be performed, or that additional relevant data be gathered and analyzed.~~

(4) The Health Officer may specify the time of year during which water table determinations are to be made.

(5) Any tests, data gathering, or analysis which the Health Officer may require as part of the application process shall be performed at the expense of the applicant.

(6) Any tests, data gathering, or analysis which the Health Officer may require as part of the application process may be required to be performed under the supervision of the Health Officer or performed by individuals certified authorized by the Health Officer to carry out such testing, data gathering, or analysis. (Ord. _____, § __, __/2017)

(7) Any tests, data gathering, or analysis which the Health Officer may require as a part of the application process shall be performed in accordance with regulations issued by the Health Officer.

(8) Each application for a permit ~~to construct a sewage disposal system~~ shall be accompanied by a filing fee in an amount sufficient to cover costs, as set by resolution or ordinance of the Board of Supervisors ~~in an amount sufficient to cover costs~~. No part of the permit filing fee shall be refundable. (Ord. 2351, § 19, 12/06/2005; Ord. _____, § __, __/2017)

(d) Inspections.

(1) Prior to ~~issuing any sewage disposal approval of any onsite wastewater treatment system permit application~~, the Health Officer shall inspect the site and review departmental records to determine the probable suitability of the site to absorb sewage ~~conduct a site inspection and review other information as needed to determine the suitability of the site for the proposed system installation~~. (Ord. _____, § __, __/2017)

(2) ~~Final inspection of each installation shall be made prior to the time the system is backfilled or covered.~~ Periodic inspections may be made by the Health Officer during the installation process. A final inspection of each installation shall be made by the Health Officer prior to the time the system is backfilled or covered. In the event that the Health Officer determines that there has been an improper installation, a stop work order or Notice of Violation may be posted on the job site. No further work may be performed until the Health Officer has determined that the improper installation has been corrected. ~~Before any further work is done on the site, clearance from the Health Officer must be obtained.~~ (Ord. _____, § __, __/2017)

~~(3) At the discretion of the Health Officer, the above work may be performed by the Building Department.~~

(e) Approval.

~~(1) If the Health Officer finds that the proposed sewage disposal system conforms to the requirements of this division, regulations issued by the Health Officer, and other pertinent laws and Code sections, and that the proposed sewage disposal system is appropriate for the sewage disposal demands of the situation, he shall issue a permit therefor. The granting of the permit shall be made subject to the terms and conditions attached thereto and made a part thereof. If the sewage disposal system requires major repair, the permit shall require the entire system to conform as closely as is possible to this division.~~

(1) Design Approval. If the Health Officer finds that the proposed onsite wastewater treatment system conforms to the requirements of this division, regulations issued by the Health Officer, and other relevant state laws, regulations, and policies, he/she shall approve the permit application. Application approval by the Health Officer signifies design approval only. The granting of design approval by the Health Officer shall be made subject to any terms and conditions attached thereto and made a part thereof. Installation of new onsite wastewater treatment systems may commence after the Health Officer has approved the application and after the applicant has obtained a building construction permit from the County Building Official. Installation of repairs to existing systems does not require a building construction permit and may commence after the Health Officer has approved the application. If the onsite wastewater treatment system requires major repair, the permit shall require the entire system to conform as closely as is possible to this division, the regulations issued by the Health Officer, and any other relevant state laws, regulations, and policies. (Ord. _____, § __, __/2017)

(2) Construction Approval. The Health Officer shall conduct a final inspection upon completion of the construction of the onsite wastewater treatment system for final approval. This final approval of the sewage disposal system by the County does not guarantee that the system will function satisfactorily. Final approval means only that the system has been installed in a manner consistent with the approved design and the terms and conditions of the permit. (Ord. _____, § __, __/2017)

(f) Denial.

(1) The Health Officer shall not issue a permit approve an application if he/she finds that the proposed sewage disposal onsite wastewater treatment system does not conform to all the requirements of this division, regulations issued by the Health Officer, and or other pertinent laws, regulations, policies, and Code sections. The Health Officer shall not approve an application if he/she or for other reasons finds the proposed sewage disposal system inappropriate design inadequate for to the sewage demands of the situation or may constitute or result in a public nuisance. (Ord. _____, § __, __/2017)

(2) The Health Officer shall give written notice to the applicant of the decision to deny the permit application. Such notice shall include the reasons for denial. Written notice shall be deemed to be received one (1) day after the notice, properly addressed, is mailed sent to the applicant by certified mail, return receipt requested. Notice shall be effective upon actual receipt or refusal as shown on the receipt obtained pursuant to the foregoing. (Ord. _____, § __, __/2017)

(g) Expiration of Permit Design Approval.

(1) New Construction or Modification Permits. Onsite wastewater treatment system design approvals for new construction or modification All sewage disposal system permits shall expire and become null and void if the work authorized thereby has not been completed and passed final inspection within one (1) year following the issuance of the building construction permit by the County Building Official. Prior to the expiration of the one (1) year period, the Health Officer may extend the term of the Design Approval permit for an up to an additional one (1) year period if presented with evidence that the work authorized can reasonably be expected to be completed during the extension period. (Ord. _____, § __, __/2017)

(2) Repair and Abandonment Permits. Onsite wastewater treatment system design approvals for repairs and abandonments shall expire and become null and void if the work authorized thereby has not been completed and passed final inspection within one (1) year following the issuance of the design approval by the Health Officer. (Ord. _____, § __, __/2017)

(h) Revocation.

(1) Any sewage disposal onsite wastewater treatment system permit or application approval may be revoked or suspended by the Health Officer if he/she determines that a violation of this division or regulations issued by the Health Officer exists; or that the permit or approval was obtained by fraud, misrepresentation, or material omission; or for any other reason that conflicts with state or local laws. Prior to revoking or suspending the permit or approval, the Health Officer must cause written notice to be mailed to the permittee or applicant and the occupant owner of the property. The notice shall specify the violation(s) and the work to be done and shall allow thirty (30) days to complete the work. The notice shall also inform the permittee or applicant of the that he has a right to an optional informal hearing before the Health Officer. (Ord. _____, § __, __/2017)

(2) If a permittee or applicant fails to comply with the pre-revocation or pre-suspension notice, the Health Officer shall send to the permittee or applicant and owner of the property a notice of revocation or suspension. The notice shall be sent by certified mail, return receipt requested. Notice shall be effective upon actual receipt or refusal as shown on the receipt obtained pursuant to the foregoing. The notice of revocation or suspension shall inform the permittee or applicant of his/her the right to file an appeal to the Board of Supervisors as set forth in § 612-3. (Ord. _____, § __, __/2017)

~~(3) The suspension or revocation of any permit shall not be effective until ten (10) days after notice thereof in writing is mailed to the permittee. (Ord. 945, § 5, 10/2/73)~~

~~612-3. LAPSE OF EXISTING PERMITS.~~

~~(a) All permits issued under Ordinances Nos. 324 and 931 shall expire on June 1, 1974, unless the work authorized thereby has been completed and has passed the final inspection. (Ord. 945, § 14, 10/2/73)~~

612-43. APPEALS.

(a) Any person affected by an approval, denial, suspension, or revocation of a permit by the Health Officer may appeal to the Board of Supervisors by filing a notice of appeal with the Clerk of the Board of Supervisors Department of Health and Human Services, Division of Environmental Health, within thirty (30) days of the action of the Health Officer or receipt of written notice by the Health Officer, whichever is later. The notice of appeal shall be accompanied by a filing fee set by resolution or ordinance of the Board of Supervisors in an amount sufficient to cover costs. The appeal shall stay the effect of the action of the Health Officer. However, no appeal may be taken concerning any action of the Health Officer which such officer is required to take pursuant to state or federal law, including the provisions of the State Regional Water Resources Quality Control Board's Water Quality Control Policy for Siting, Design, Operation, and Maintenance of Onsite Wastewater Treatment Systems Basin Plan. (Ord. 2067, § 1, 04/25/95; Ord. 2351, § 19, 12/06/2005; Ord. _____, § __, __/2017)

(b) The appeal shall be in writing and addressed to the Board of Supervisors Department of Health and Human Services, Division of Environmental Health. The appellant applicant shall also file a copy of the appeal with the Health Officer on the day of filing with the Clerk of the Board of Supervisors on the same day of filing with the Division of Environmental Health. In the notice of appeal, the appellant shall specifically identify the action taken by the Health Officer that the appellant is challenging and the date of the action, as well as state in full the facts and circumstances which make the action of the Health Officer unreasonable, including citations to any applicable laws or regulations. It shall also state the date of the claimed unreasonable action of the Health Officer. Failure to comply with these appeal procedures will render the notice of appeal invalid and will not toll the time allotted to file a notice of appeal. (Ord. _____, § __, __/2017)

(c) Upon receipt of a timely notice of appeal, the Board of Supervisors shall cause the matter to be set for hearing not earlier than twenty (20) calendar days after the notice of appeal has been filed with the Division of Environmental Health and the Clerk of the Board. The Clerk of the Board Board of Supervisors, in its discretion and upon stipulation of the Health Officer and appellant, may set the hearing on an expedited schedule. The Division of Environmental Health shall cause notice to be mailed to all affected persons at least ten (10) calendar days prior to the hearing. (Ord. _____, § __, __/2017)

(d) At the time and place set for the hearing, the Board shall proceed to hear the testimony of the Health Officer, the testimony of the owner or his/her representatives, and the testimony of other competent persons concerning the conditions upon which the action of the Health Officer is based and other matters which the Board may deem pertinent. Any person affected may be present at such hearing, may be represented by counsel, may present testimony, and may cross-examine the Health Officer and other witnesses. The hearing may be continued from time to time at the discretion of the Board of Supervisors. (Ord. _____, § __, __/2017)

The Health Officer may cross-examine the appellant and other witnesses and may be represented by counsel. At the request of the Health Officer, the County Counsel shall represent the Health Officer.

(e) "Any person affected" shall include, but not be limited to, the applicant or his/her agent, the owner of the affected property or his/her agent, and the owners or their agents of all adjoining properties to the property against which the action of the Health Officer is directed.

(f) The Board may, upon the appeal, either affirm the action of the Health Officer or grant a variance to the provisions of this division or regulations issued by the Health Officer upon which the action under appeal is based. No variance may be granted with respect to any requirement established pursuant to state or federal law, regulation, or rule, including requirements of the State ~~Regional~~ Water Resources Quality Control Board's Water Quality Control Policy for Siting, Design, Operation, and Maintenance of Onsite Wastewater Treatment Systems Basin Plan. The decision of the Board of Supervisors upon an appeal shall be based upon the facts presented to it. (Ord. 945, § 6, 10/2/73; Ord. 2067, § 1, 04/25/95; Ord. _____, § __, __/ /2017)

(g) Failure to challenge the Board's decision within 45 days shall be deemed to be a waiver of any objection to the Board's decision. (Ord. _____, § __, __/ /2017)

612-54. INVESTIGATION AND ABATEMENTS.

(a) Whenever it is necessary to make an inspection to determine compliance with the provisions of this division, the Health Officer may enter any buildings or place at all reasonable times to inspect the same or to perform any duty imposed upon the Health Officer by this division; provided that, if such building or place be occupied, he/she shall first present proper credentials and demand entry; and, if such building or place be unoccupied, he/she shall first make a reasonable effort to locate the owner or other persons having charge or control of the building or place and demand entry. If such entry is refused, the Health Officer ~~or his authorized representative~~ shall have recourse to every remedy provided by law to secure entry. (Ord. _____, § __, __/ /2017)

(b) In the event a ~~sewage disposal system or wastewater treatment system~~ subject to this division is operated, constructed, or repaired contrary to the terms of this division or regulations issued by the Health Officer, the Health Officer may send written notice to the owner of the land as shown on the most recent equalized assessment roll, at his/her address listed on said roll. Said notice shall state the manner in which the ~~sewage disposal~~ system is in violation, what corrective measures must be taken, the time within which such corrections must be made, and, that if the land owner fails to make corrections within the period provided, the corrections may be made by the County and the land owner shall be liable for the costs thereof. (Ord. _____, § __, __/ /2017)

(c) If the corrections listed on the notice are not made as required in said notice, the Health Officer shall abate the nuisance or violation pursuant to §§ 3651-1 et seq. The notice permitted by this subsection need not be given prior to abating the nuisance or violation pursuant to §§ 3651-1 et seq. (Ord. 945, § 8, 10/2/73; Ord. _____, § __, __/ /2017)

612-65. DECLARATION OF PUBLIC NUISANCE.

The following are hereby declared to be a public nuisance:

(a) The presence of sewage upon the surface of the ground ~~in urban and suburban areas~~. (Ord. _____, § __, __/ /2017)

(b) ~~a~~ A sewage disposal treatment system which creates a public nuisance as defined in § 611-2(k). (Ord. _____, § __, __/ /2017)

(c) A ~~sewage disposal treatment~~ system which empties, flows, seeps, or drains into any surface waters or can reasonably be expected to do so. (Ord. _____, § __, __/ /2017)

(d) A sewage ~~disposal~~ treatment system which now does or may reasonably be expected to empty, flow, or drain into or adversely affect any subsurface water which is used or is suitable for use by any inhabitants of the State. (Ord. ____, § __, __/2017)

This declaration of public nuisance is not intended to be an exclusive definition of public nuisance or a limitation upon the authority of the Health Officer to declare other circumstances to be a public nuisance. (Ord. 945, § 9, 10/2/73; Ord. ____, § __, __/2017)

612-76. PENALTY.

It shall be unlawful for any person, firm, or corporation to violate, refuse or fail to comply with any of the provisions of this division. (Ord. 945, § 20, 10/2/73; Ord. ____, § __, __/2017)

Failure to comply with any of the provisions of this division may result in an abatement proceeding, as set forth in § 351 et seq. of the Humboldt County Code, and/or the imposition of civil administrative penalties, as set forth in § 352 et seq. of the Humboldt County Code. (Ord. ____, § __, __/2017)

612-87. RESPONSIBILITY FOR DAMAGE.

This division shall not be construed as imposing upon the County of Humboldt any liability or responsibility for damage resulting from the defective installation of any sewage ~~disposal~~ treatment system as herein provided, nor shall the County of Humboldt or any official or employee thereof be held as assuming any such liability or responsibility by reason of the inspection authorized thereunder. (Ord. 945, § 13, 10/2/73; Ord. ____, § __, __/2017)

CHAPTER 3

PROHIBITIONS

613-1. GENERAL PROHIBITIONS.

(a) No permit shall be issued if the operation of the proposed sewage ~~disposal treatment~~ system would tend to create a public nuisance as defined in § 611-2(k). (Ord. _____, § __, __/ /2017)

(b) No application shall be accepted if the proposed development of the site would violate any Code sections enacted by the Board of Supervisors or would be inconsistent with the General Plan, the Zoning Title, or the Open Space Conservation Plan, the Water Quality Control Policy for Siting, Design, Operation, and Maintenance of Onsite Wastewater Treatment Systems, or any other applicable policies and regulations of the State Water Resources Control Board. (Ord. _____, § __, __/ /2017)

(c) No permit shall be issued if the operation of the proposed sewage ~~disposal treatment~~ system would violate any laws, regulations, or policies of the State of California. (Ord. _____, § __, __/ /2017)

(d) It shall be unlawful for any person to deposit, by any means whatsoever, into any plumbing fixture, floor drain, interceptor, sump, receptacle or device which is connected to any drainage system, public sewer, sewage ~~disposal treatment~~ system or septic tank any ashes, cinders, solids, rags, flammable, poisonous or explosive liquids or gases, oils, grease, and any other thing whatsoever which ~~would, or could,~~ may cause damage to the public sewer or private sewage ~~disposal treatment~~ system. (Ord. 945, § 19, 10/2/73; Ord. _____, § __, __/ /2017)

613-2. CESSPOOLS AND WASTE WELLS PROHIBITED.

All cesspools and waste wells are hereby declared to be public nuisances. It shall be unlawful to drill, construct, maintain, use, or operate a cesspool or waste well. (Ord. 945, § 11, 10/2/73)

613-3. ~~BORED PITS AND~~ SEEPAGE PITS PROHIBITED.

~~Bored pits and s~~seepage pits ~~tend to~~ have the same undesirable characteristics of cesspools and waste wells. It shall be unlawful to dig or bore seepage pits ~~or bored pits~~. (Ord. 945, § 11, 10/2/73; Ord. _____, § __, __/ /2017)

613-4. PRIVIES PROHIBITION OF HOLDING TANKS; PORTABLE TOILETS; VAULT TOILET.

(a) The use of holding tanks is prohibited except as provided below: (Ord. _____, § __, __/ /2017)

(1) The Health Officer authorizes use of a holding tank as a temporary means to abate an existing nuisance or health hazard; or (Ord. _____, § __, __/ /2017)

(2) The proposed use is within a sewer service area, sewers are under construction or contracts have been awarded and completion is expected within two (2) years, there is capacity at the wastewater treatment plant and a public entity will assume responsibility for maintenance of the tanks; or (Ord. _____, § __, __/ /2017)

(3) Use at a campground or similar temporary public facility where a permanent sewage treatment system is not necessary or feasible and maintenance is performed by a public agency. (Ord. _____, § __, __/ /2017)

(b) Portable toilets shall be limited to serve non-residential, temporary-use or occasional-use activities such as remove or field labor operations, special events, and temporary construction sites where connection to a public sewer system or installation of an OWTS is not practicable. (Ord. _____, § __, __/ /2017)

(1) No permit is required for use of portable toilets. (Ord. _____, § __, __/ /2017)

(c) The use of vault toilets or portable toilets at a temporary-use public facility such as a beach, park or campground may be allowed by the Health Officer where the vault toilet is necessary for the public health, safety, or welfare, where installation of an OWTS is not feasible, where the vault toilet is determined to provide the safest and most acceptable method of sewage handling and is maintained by a public entity. (Ord. _____, § __, __/ /2017)

(d) Portable toilet and vault toilet siting shall conform to setbacks for septic tanks as provided in regulations issued by the Health Officer. (Ord. _____, § __, __/ /2017)

613-45. PIT PRIVIES.

It shall be unlawful to construct, maintain, or use a pit privy except as provided below:

(a) A pit privy may be used in conjunction with a dwelling constructed pursuant to Article 10, Title 25, California Code of Regulations. A pit privy may also be used as an auxiliary sewage ~~disposal~~ treatment system for a dwelling which is served by a conventional septic tank-leachfield sewage ~~disposal~~ treatment system or in campgrounds where other liquid wastes requiring sewage disposal are not generated. (Ord. 2351, § 20, 12/06/2005; Ord. _____, § __, __/ /2017)

(b) A pit privy shall be located only in a rural area. For the purpose of this section "rural" is defined as that part of Humboldt County which is outside the boundaries of an incorporated city, a community services district, a sphere of influence as designated by ~~LAPCO~~ the Local Agency Formation Commission, or a city established planning area (Government Code § 65300) in the absence of an official city sphere of influence, ~~or~~ or outside an urban limit line as designated in the Humboldt County Coastal Land Use Plans; or which is within a community services district or sphere of influence which is located beyond the reasonably projected availability of community services, and which is zoned to permit residential use either as a principal use or with a conditional use permit. (Ord. _____, § __, __/ /2017)

(1) For purposes of this section "community services" means water or sewer.

(2) If there is any question that land for which a permit is being sought under this section is located beyond the reasonably projected availability of community services, the matter shall be resolved by obtaining from the appropriate city or community services district a written statement indicating whether the city or district intends to serve the parcel in question in the foreseeable future. The written answer of the city or district shall be conclusive as to whether the land for which a permit is sought is located beyond the reasonably projected availability of community services.

(c) A pit privy shall be allowed only on a parcel of land two (2) acres or greater in size.

(d) A pit privy shall be allowed for a dwelling only when the proposed building site has been evaluated and the site has been determined to be suitable for the installation of a conventional septic tank-leachfield sewage ~~disposal~~ treatment system and reserve area. A determination that there is adequate area for the installation of a conventional sewage ~~disposal~~ treatment system and reserve area shall not be necessary when a pit privy is proposed to be used to attempt to repair a failing sewage ~~disposal~~ treatment system that cannot be corrected due to local conditions such as soil percolation value, high groundwater, or insufficient area. (Ord. _____, § __, __/ /2017)

(e) A pit privy shall be located in an area suitable for the installation of a conventional septic tank-leachfield sewage ~~disposal~~ treatment system. However, no pit privy shall be located closer than fifty feet (50') to a property line. The Health Officer may waive the fifty feet (50') property line setback when the adjoining property owner agrees to the waiver in writing. (Ord. _____, § __, __/ /2017)

(f) A dwelling which has a pit privy and which is not connected to a conventional septic tank-leachfield sewage ~~disposal~~ treatment system shall be connected to a graywater ~~disposal~~ system approved by the Health Officer. Graywater systems are addressed in Chapter 7 of this division. (Ord. _____, § __, __/ /2017)

~~(g) For the purposes of this section, a pit privy is defined as an earthen pit which is covered with a structure and is intended for the disposal of human body wastes.~~

(hg) The Health Officer shall adopt regulations in accordance with § 621 12-1 of this Code, which will determine the site criteria, construction standards, and maintenance standards for pit privies and graywater ~~disposal~~ systems. Such regulations shall require that a pit privy be a sanitary pit privy constructed in a manner to exclude flies and other possible disease vectors from the earthen pit. The regulations adopted shall also provide that pit privies and graywater systems be constructed only in a manner which will prevent pollution or contamination of groundwater or surface water. The regulations shall further provide that pit privies and graywater systems be maintained in such a manner as to prevent the spread of communicable disease and nuisance conditions. (Ord. 945, § 12, 10/2/73; Ord. 1565, § 1, 11/30/82; Ord. _____, § __, __/ /2017)

CHAPTER 4

MORATORIA

614-1. MORATORIA.

In areas where sewage ~~disposal~~ treatment systems represent existing or potential community contamination problems, the Board of Supervisors may declare a moratorium on the issuance of sewage ~~disposal~~ treatment system permits. Information shall be gathered by the Health Officer regarding the nature of current and potential problems in such areas. Factors involved in the declaration of a moratorium include, but are not limited to: (Ord. _____, § __, __/ /2017)

- (a) High ground water during any part of the year;
- (b) Soil conditions;
- (c) Geologic conditions;
- (d) Failed systems in the area;
- (e) Density of dwellings;
- (f) Load on the system or systems;
- (g) Land use patterns;
- (h) Nuisance hazard; and
- (I) Other factors as may be identified by the Health Officer.

The Health Officer shall keep on file maps showing the moratorium areas and shall inform other permitting agencies and local financial institutions of the action of the Board of Supervisors. (Ord. 945, § 17, 10/2/73)

CHAPTER 5

EXPERIMENTAL DISPOSAL SYSTEM PROGRAM**615-1. PURPOSE.**

These regulations are intended to provide alternatives to conventional sewage ~~disposal~~ treatment systems by permitting the use of experimental on-site disposal systems. The purpose of the experimental ~~on-site~~ disposal system program is to allow volunteers to install viable, innovative experimental disposal systems while protecting public health and water quality. (Ord. 1647, § 1, 7/24/84; Ord. _____, § __, __/2017)

615-2. GENERAL REQUIREMENTS.

(a) Experimental disposal systems ("EDS" or "system") generally require ongoing, periodic maintenance which extends for the life of the system. Therefore, experimental systems will be allowed in any one or more of the following limited and controlled circumstances: (Ord. _____, § __, __/2017)

(1) The site on which the EDS is proposed to be installed has an approved conventional sewage ~~disposal~~ treatment system currently in operation and the experimental system would be an accessory thereto. (Ord. _____, § __, __/2017)

(2) The site has a failing sewage treatment system that cannot be corrected due to local conditions, such as soil percolation value, high groundwater, insufficient area, and the experimental system would attempt to reduce the existing negative impact upon the environment. (Ord. _____, § __, __/2017)

(3) The site is beyond the reasonably projected availability of community services and has suitable area approved for the installation of a standard individual sewage ~~disposal~~ treatment system and reserve area. In addition, an EDS existing prior to January 1, 1984, where testing has established that a suitable area approved for the installation of a conventional sewage ~~disposal~~ treatment system and reserve area does not exist, may participate in the EDS program. (Ord. _____, § __, __/2017)

(4) The site is within a specially created maintenance district designed to monitor and maintain all sewage ~~disposal~~ treatment systems within the district. (Ord. _____, § __, __/2017)

(b) Experimental disposal systems may be allowed for single family dwellings located on owner-occupied property, subject to the provisions of these regulations. (Ord. 1647, § 1, 7/24/84)

615-3. APPLICANTS' QUALIFICATIONS.

Applicants for an EDS shall demonstrate their knowledge regarding the health concerns, composting, wastewater treatment, and design, installation, maintenance and ~~operating~~ operation of experimental on-site disposal systems. The Experimental Disposal Systems Manual may be obtained at The Department of Health and Human Services, Division of Environmental Public Health. Department has developed a manual which outlines the information necessary which is attached hereto as Appendix A. Applicants must successfully complete a written examination at the Health Department. Applicants must successfully complete a written examination at the Division of Environmental Health. (Ord. 1647, § 1, 7/24/84)

615-4. PERMITS.

(a) Any person who wishes to install an EDS on any parcel of land may do so only after applying for and obtaining a permit for ~~that~~ purpose from the Department of Health and Human Services, Division of Environmental Public Health Branch. Any such permit may be issued only if the applicant qualifies for the permit under the provisions of this chapter. (Ord. 2351, § 21, 12/06/2005; Ord. _____, § __, __/2017)

(b) Applicants who successfully complete the examination as indicated in § 615-3 shall be eligible for issuance of an operating permit for an EDS.

(c) Operating permits shall be valid for a period of five (5) years. Operating permits may be extended for a period of one (1) year provided that evidence is submitted which indicates that an extension is necessary to complete final testing of the unit. A maximum of three (3) such extensions may be granted.

(d) Permits shall be issued for experimental design proposals which indicate that the system can be operated without violating the revocation conditions listed below or the provisions of § 615-6 ~~and 615-7~~. (Ord. _____, § __, __/2017)

(e) Operating permits and extensions granted pursuant to the provisions of these regulations may be revoked during the experimental period under any of the following conditions:

- (1) An unsanitary condition caused by the system exists.
- (2) There is improper use or disposal of the system end product.
- (3) The dwelling which is served by the system is no longer occupied by the person to whom the permit is issued.
- (4) The system is no longer being maintained by the permittee.
- (5) The system is being operated in a manner resulting in groundwater or surface water contamination.
- (6) The system is being operated in violation of conditions for approval of the operating permit.

(f) Before revocation of any operating permit, the permittee shall have an opportunity to be heard regarding the matter upon which a proposed revocation is based. The hearing shall be before a hearing officer designated by the County Health Officer. Any determination of the hearing officer may be appealed to the Board of Supervisors within thirty (30) days of such determination.

(g) It shall be the duty of the County Health Officer to cause to be filed with the Humboldt County Recorder a notice of each operating permit issued pursuant to these regulations. The notice shall refer to the provisions of this chapter, shall identify the locations of the site where the system is located by Assessor's parcel number or any other appropriate description. A notice form shall be prepared by the Department of Health and Human Services, Division of Environmental Health Public Health Branch. An appropriate notice shall also be recorded by the Health Officer when the EDS is converted to a standard system. (Ord. 1647, § 1, 7/24/84; Ord. 2351, § 21, 12/06/2005; Ord. _____, § __, __/2017)

615-5. INFORMATION SHARING.

(a) Each person who has obtained a permit to operate an EDS shall provide the Department of Health and Human Services, Division of Environmental Public Health, Branch with a summary of his or her findings on a yearly basis at a time designated by the ~~Department of~~ Division of Environmental Health and Human Services Public Health Branch. This summary shall include, but not be limited to, the following: (Ord. 2351, § 21, 12/06/2005; Ord. _____, § __, __/2017)

(1) A description of operational procedures used for the system during the test period. This description shall include initial operational and maintenance procedures and any changes to those procedures during the year.

(2) The result of any physical and biological testing conducted for the system.

(3) Methods of disposal of end product from the system.

(4) Any operational and maintenance problems which were encountered and the methods which were used to resolve the problems.

(5) Planned activities for operation of the system during the ensuing year.

(6) ~~Other recommendations or comments~~ Any other information requested by the Department of Health and Human Services, Division of Environmental Health. (Ord. 1647, § 1, 7/24/84; Ord. _____, § __, __/2017)

615-6. WATERLESS TOILET SYSTEMS.

Waterless toilet systems under the provisions of this experimental program shall be subject to the following requirements:

(a) Disposal of the end product from a disposal system shall be prohibited in the following areas:

(1) Shallow subsurface disposal in present or planned food crop growing areas or dairy pasture.

(2) Area subject to seasonal runoff or areas seasonally inundated by water.

(3) Areas within 50 feet (50') of ephemeral streams or 100 feet (100') of perennial streams.

(b) The following methods of end product disposal shall be acceptable:

(1) Direct burial with a minimum of 18 inches (18") of compacted soil is the preferred method of disposal of end product prior to final designation of an experimental unit as a prototype.

(2) Disposal into an approved, conventional sewage disposal system.

(3) Shallow, subsurface disposal by tilling or a similar technique may be acceptable when the applicant proposes to use the method as part of the treatment system. Final approval of this method shall be based upon the treatment method proposed and a field review of the site proposed.

Sites proposed for shallow subsurface disposal shall have access restricted to the operator of the waste disposal system. Surface distribution of end product prior to tilling shall be at a maximum thickness of one-half inch (½"). Tilling shall be carried out immediately after surface distribution is completed. Surface distribution shall be timed to avoid sheet flows of water caused by rainfall.

(4) End product disposal shall be carried out by methods 1 or 2 above whenever an individual using an experimental unit has a communicable disease which can be transmitted by human waste contamination of food or water.

(c) The proposed system shall include a monitoring and maintenance plan.

(d) The experimental unit shall be constructed using materials and methods which resist the corrosive effects of waste material and which will be structurally sound. (Ord. 1647, § 1, 7/24/84)

~~615-7. GREYWATER DISPOSAL SYSTEMS.~~

~~(a) Experimental greywater disposal system proposals shall be subject to the following requirements.~~

~~(1) Soil at the site shall have adequate percolation capability.~~

~~(2) Proposed installations shall meet the site requirements of the North Coast Regional Water Quality Control Board's "Basin Plan Septic Tank Policy" with respect to site characteristics in relation to groundwater conditions, saturated soil conditions and proximity to streams.~~

~~(3) Disposal of effluent from a greywater disposal system shall occur in such a manner as to prevent the contamination of surface or groundwater, to prevent contact of the greywater with disease or nuisance vectors and to prevent offensive odors or other similar conditions from occurring.~~

~~(4) The experimental system shall be constructed using materials and methods that will enable the system to resist the corrosive effects of waste material and that will result in a system that is structurally sound. (Ord. 1647, § 1, 7/24/84)~~

~~615-87. PROTOTYPE EXPERIMENTAL SYSTEMS.~~

~~(a) An experimental disposal system may be designated as a prototype disposal system prior to the expiration of an experimental operation permit whenever it is demonstrated that the treatment process has effectively and reliably functioned during the experimental period.~~

~~(b) The following standards shall be met for designation of waterless toilets.~~

~~(1) The process must exclude disease vectors and must not spread communicable diseases.~~

(2) Waste materials, intermediate products, or finished product must not contaminate or pollute surface or groundwater or otherwise significantly degrade the environment.

(3) The process must result in a minimum reduction of volatile solids of 30 percent (30%) testing conducted at least twice annually.

(4) The process must result in a finished product with less than 500 fecal coliform bacterial per gram of sludge in tests conducted twice annually.

~~(c) The following standards shall be met for designation of greywater systems:~~

~~_____ (1) The process must exclude disease vectors and must not spread communicable disease.~~

~~_____ (2) Waste material, intermediate products or finished product must not contaminate or pollute surface or groundwater or otherwise significantly degrade the environment.~~

~~_____ (3) The finished product of the treatment process must be disposed of by percolation into the ground, evaporation or by disposal into a conventional sewage disposal system.~~

(dc) The Health Department Officer shall review the standards listed above and make recommendations for changes to the Board of Supervisors within three (3) years after the adoption of this chapter. The Board of Supervisors shall appoint a citizens advisory committee to participate in the review. (Ord. _____, § __, __/ /2017)

(ed) Experimental units which meet the specified standards at the end of the five (5) year period and any extensions thereof granted shall be designated as a prototype. (Ord. _____, § __, __/ /2017)

(fe) Permit holders who have operated a designated prototype during the experimental period shall not be subject to semiannual inspections or fees for that prototype unit. (Ord. _____, § __, __/ /2017)

(gf) Persons applying for a permit to construct or operate a prototype who have not previously successfully operated that prototype under an operating permit shall obtain an operating permit and be subject to semiannual inspections for the first two years after the system is initiated. Thereafter, the applicant shall demonstrate the ability to successfully operate the prototype unit. (Ord. _____, § __, __/ /2017)

(hg) Review and designation of experimental units as prototype units shall be the responsibility of the County Health Officer. (Ord. 1647, § 1, 7/24/84; Ord. _____, § __, __/ /2017)

615-98. INSPECTIONS.

(a) All experimental installations shall be owner-operated and subject to inspection by the Department of Health and Human Services, Division of Environmental Public Health, Branch upon reasonable notice. Routine inspections shall be conducted upon two (2) weeks advance notice or prearranged appointment by the Division of Environmental ~~Department of Health and Human Services Public Health Branch~~ two times yearly. Additional inspections may be made if significant operational problems, health hazards, or nuisance conditions are noted during the routine inspections or upon receipt of a citizen's complaint. The holder of an experimental operation may request additional inspections. (Ord. 2351, § 21, 12/06/2005; Ord. _____, § __, __/2017)

(b) The cost of all inspections shall be paid by the holder of an experimental operation permit. (Ord. 1647, § 1, 7/24/84)

CHAPTER 6

MAINTENANCE OVERSIGHT OF NON-STANDARD
~~WATER CARRIED SEWAGE DISPOSAL~~ ONSITE WASTEWATER TREATMENT SYSTEMS

616-1. INTENT.

The intent of this article is to assure that non-standard, ~~water-carried sewage disposal~~ wastewater treatment systems are periodically inspected to assure that they function properly and that any necessary maintenance is completed in an expeditious manner. (Ord. _____, § __, __/2017)

616-2. DEFINITIONS.

For the purposes of this chapter, the following definitions shall apply:

(a) Standard system: a method of water-carried, onsite ~~sewage disposal~~ wastewater treatment system which includes a septic tank (with or without a sump and pump) by which effluent is ~~disposed of~~ carried through subsurface leach lines which are constructed in accordance with § 612-1 of this ~~c~~Code. The septic tank in a standard system uses no mechanical device to aid treatment of sewage. (Ord. _____, § __, __/2017)

(b) Non-standard system:

(1) Any water-carried ~~sewage disposal~~ onsite wastewater treatment system which uses a pretreatment unit for sewage treatment (*e.g.* aerobic treatment units, packed bed filters, sand filters); or (Ord. 2374, § 1, 12/05/2006; Ord. _____, § __, __/2017)

(2) Any water-carried ~~sewage disposal~~ onsite wastewater treatment system that does not use subsurface leach lines for effluent ~~disposal~~ dispersal (*e.g.* Wisconsin Mounds or At-Grades); or (Ord. 2374, § 1, 12/05/2006; Ord. _____, § __, __/2017)

(3) Any water-carried ~~sewage disposal~~ onsite wastewater treatment system where the pump tank and leach lines are connected by a pipe which exceeds 500 feet in length; or (Ord. 2374, § 1, 12/05/2006; Ord. _____, § __, __/2017)

(4) Any system receiving flows greater than 1500 gallons per day; or (Ord. _____, § __, __/2017)

(~~4~~5) Any other system the Department shall deem non-standard, including but not limited to, pressure distribution systems, drip dispersal systems, and constructed wetlands. (Ord. 2159, § 1, 02/10/1998; Ord. 2374, § 1, 12/05/2006; Ord. _____, § __, __/2017)

(c) Department: Department of Health and Human Services, Division of Environmental Health ~~Division~~. (Ord. 2374, § 1, 12/05/2006; Ord. _____, § __, __/2017)

~~(d) Qualified consultant: A Registered Civil Engineer, Registered Environmental Health Specialist, Professional Geologist, or Certified Soil Scientist who has experience designing non-standard sewage disposal systems. (Ord. 2374, § 1, 12/05/2006)~~

(~~ed~~) Qualified service provider: A person who shall demonstrate all of the following: (Ord. 2374, § 1, 12/05/2006; Ord. _____, § __, __/2017)

(1) California License: C-42 or C-36 Plumbing Contractor, or Class A General Engineering Contractor. (Ord. 2374, § 1, 12/05/2006)

(2) Education: Third party inspection and maintenance certification from a recognized institution (e.g. NSF, COWA, CEHA, CWEA, NOWRA, or approved equivalent). (Ord. 2374, § 1, 12/05/2006)

(3) Experience: Minimum of two (2) years experience installing non-standard ~~sewage disposal onsite wastewater treatment~~ systems, including a minimum of ten (10) ~~non-standard sewage disposal~~ such systems installed and approved by the Department. (Ord. 2374, § 1, 12/05/2006; Ord. _____, § __, __/2017)

616-3. OPERATIONAL PERMIT REQUIRED FOR NON-STANDARD SYSTEMS.

(a) No person, firm, corporation or other entity shall use, or cause or allow the use of any non-standard system within the unincorporated area of Humboldt County unless a valid operational permit is in effect for ~~such use that system~~. This permit shall be applied for and issued on an application form provided by the Department. Use of a non-standard system without a valid permit is a violation of this chapter, and subject to all of the remedies authorized by state law or this ~~cCode~~. (Ord. 2374, § 1, 12/05/2006; Ord. _____, § __, __/2017)

(b) Experimental Disposal Systems as ~~defined regulated in § 615-6 or 615-7 Chapter 5~~ of this ~~cCode~~ shall not be subject to the provisions of this chapter. (Ord. _____, § __, __/2017)

(c) The Board of Supervisors shall establish a fee ~~or as or schedule or of~~ fees for operational permits, to be collected by the Department. (Ord. 2159, § 2, 02/10/1998; Ord. 2374, § 1, 12/05/2006; Ord. _____, § __, __/2017)

(d) Upon payment of all fees and submission of an application which demonstrates to the Department's satisfaction that the system will not have an adverse effect on ground or surface waters or upon public health, an Operational Permit shall be issued. ~~The Director of the Department Health Officer~~ may issue such regulations as are necessary to carry out the provisions of this chapter. (Ord. 2159, § 2, 02/10/1998; Ord. 2374, § 1, 12/05/2006; Ord. _____, § __, __/2017)

(1) Operational Permits are valid for a period of three (3) years from the date of issuance unless revoked by the Department. (Ord. 2374, § 1, 12/05/2006; Ord. _____, § __, __/2017)

(2) Operational Permits may be renewed in accordance with the terms of the permit, upon submittal of a complete application, payment of the required fee, and submittal of inspection results demonstrating continued proper maintenance and operation of the system as designed and constructed. (Ord. 2374, § 1, 12/05/2006)

(3) Operational Permits must also be renewed at the time of property sale or, in the case of commercial properties, upon change in occupants or change of use. (Ord. 2374, § 1, 12/05/2006)

(4) Operation of a non-standard ~~sewage disposal onsite wastewater treatment~~ system prior to the issuance of an Operational Permit, or without a currently valid operating permit, or after revocation of a permit, shall be deemed a violation of the provisions of this chapter. (Ord. 2374, § 1, 12/05/2006; Ord. _____, § __, __/2017)

(e) Upon issuance of ~~a permit for a non-standard sewage disposal~~ final construction approval for non-standard onsite wastewater treatment system, the Department shall cause a notice to be recorded on the property title indicating that a non-standard ~~sewage disposal~~ onsite wastewater treatment system has been installed on the parcel and that an operational permit is required. This notice is intended to alert subsequent property owners of the existence of the non-standard ~~sewage disposal~~ onsite wastewater treatment system. (Ord. 2159, § 2, 02/10/1998; Ord. 2374, § 1, 12/05/2006; Ord. _____, § __, __/2017)

(f) The owner of a parcel on which a non-standard ~~sewage disposal~~ onsite wastewater treatment system has been installed shall not interfere with the Department's right to enter onto the parcel to inspect the property to assure compliance with the provisions of this chapter. The owner shall make all components of the system accessible during the inspection (*e.g.*, tank lids, pump control panel, and absorption area). (Ord. 2159; § 2, 02/10/1998; Ord. 2374, § 1, 12/05/2006; Ord. _____, § __, __/2017)

(g) Upon issuance of an operational permit, the Department shall cause to be performed a minimum of one inspection during wet weather conditions within the term of the permit. If deficiencies are identified, additional inspections may be required and additional fees may be imposed. Failure to correct deficiencies as directed by the Department may result in subsequent inspections, additional fees, or revocation of the permit. The inspections required by this section shall include the following factors: (Ord. 2159, § 2, 02/10/1998; Ord. 2198, § 1, 10/19/1999; Ord. 2374, § 1, 12/05/2006)

- (1) Daily rainfall in Eureka for the previous thirty (30) days;
- (2) Observation of the water level in any monitoring well required as part of the ~~sewage disposal~~ wastewater treatment system permit; (Ord. _____, § __, __/2017)
- (3) Recording of domestic water use where available;
- (4) Occupancy load;
- (5) Soil moisture conditions;
- (6) Vegetation and growth conditions;
- (7) Erosion and drainage;
- (8) Available information concerning maintenance performed on the non-standard ~~sewage~~ onsite wastewater treatment system (*e.g.* replacing a pump or pump float switch, pumping the septic tank, or flushing laterals); (Ord. 2374, § 1, 12/05/2006; Ord. _____, § __, __/2017)
- (9) Condition of all ~~sewage~~ components of the non-standard ~~sewage~~ onsite wastewater treatment system; (Ord. _____, § __, __/2017)
- (10) Other information that may be available and pertinent to the operation of the non-standard ~~sewage~~ onsite wastewater treatment system. (Ord. 2198, § 1, 10/19/1999; Ord. _____, § __, __/2017)

(h) The property owner shall have the option of contracting with a Qualified consultant Professional, as defined in § 611-2(n), or Qualified Service Provider, as defined in § 612-2(d), to perform the required inspection. ~~who meets the minimum requirements of Section 616-2(d) or (3) If this option is selected, written verification from the consultant/service provider must be submitted to the Department within thirty (30) days of receipt of the Operational Permit application.~~ Upon issuance of an Operational Permit, the Qualified Professional consultant or Qualified Service Provider shall cause to be performed a minimum of one inspection during wet weather conditions within the term of the permit. If deficiencies are identified, additional inspections may be required and additional fees may be imposed. Failure to correct deficiencies as directed by the Department may result in subsequent inspections, additional fees, or revocation of the permit. Inspection reports prepared by Qualified Professionals consultants or Qualified Service Providers must be submitted within fifteen (15) days of completion, on an inspection form approved by the Department. The inspections required of this section shall include the information listed in numbers 1-10 of ~~Section G~~ § 616-3(g) set forth above. (Ord. 2159, § 2, 02/10/1998; Ord. 2374, § 1, 12/05/2006; Ord. _____, § __, __/2017)

(I) The property owner may apply for a Homeowner-Inspected Operational Permit if all the following conditions are met: (Ord. 2374, § 1, 12/05/2006)

- (1) A valid Operational Permit has been in effect for a minimum of six (6) years; (Ord. 2374, § 1, 12/05/2006)
- (2) All required inspections have been completed; (Ord. 2374, § 1, 12/05/2006)
- (3) The system is not failing; (Ord. 2374, § 1, 12/05/2006)
- (4) The system has been properly maintained; (Ord. 2374, § 1, 12/05/2006)
- (5) The minimum following components are present and maintained in good repair: lateral end sweeps and caps, tank risers and lids, effluent filter, functioning alarm and pump floats, and pump control panel. (Ord. 2374, § 1, 12/05/2006)

A Homeowner-Inspected Operational Permit will be issued upon payment of fees and shall be in effect for a period of three (3) years. Renewal of a Homeowner-Inspected Operational Permit requires an application, a fee, and results of a completed inspection. Homeowner-Inspected Operational Permits shall revert to Operational Permits at the time of property sale or when inspections are not being completed and submitted to the Department. This permit may be revoked if maintenance or operational problems are not being corrected in a timely manner. Selection of this option does not preclude oversight from the Department, including inspections. Upon issuance of a Homeowner-Inspected Operational Permit, the homeowner shall cause to be performed a minimum of one inspection during wet weather conditions within the term of the permit. Additional inspections may be required in cases where deficiencies occurring in the system have been identified. Failure to correct deficiencies in accordance with written directions may result in additional re-inspection fees. The inspections required of this section are listed in numbers 1 - 10 of ~~Section G~~ § 616-3(g). Inspection reports prepared by the homeowner must be submitted within fifteen (15) days of completion, on an inspection form approved by the Department. (Ord. 2374, § 1, 12/05/2006; Ord. _____, § __, __/2017)

616-4. REVOCATION.

(a) If the Department determines that a non-standard onsite wastewater treatment system for which a permit has been granted may have an adverse effect upon the ground or surface waters, or upon the public health, or may have a significant effect upon the environment, the permit may be revoked by the Department after notice of the proposed action has been ~~mailed~~ sent by certified mail to the permittee, and the permittee has been given an opportunity to respond at a given time and place. (Ord. 2374, § 1, 12/05/2006; Ord. _____, § __, __/__/2017)

(b) Upon a determination by the Department that immediate action is required to prevent an adverse effect upon public health, or upon surface or ground waters, the permit may be summarily revoked. Summary revocation shall be followed within seven (7) days by notice of the action mailed to the permittee, setting a time and place for response within ten (10) days of the date of mailing. (Ord. 2374, § 1, 12/05/2006; Ord. _____, § __, __/__/2017)

(c) A revoked permit may be reinstated if the Department determines that a plan has been established for adequate repair, alteration and/or maintenance of the system, and all costs of enforcement, including attorney fees, violation reinspection fees and any of the costs described in § 616-5 have been paid. (Ord. 2374, § 1, 12/05/2006)

616-5. ABATEMENT.

In any action, judicial or administrative, to enforce any provision of this Code relating to onsite sewage ~~disposal-treatment~~, the County may recover all of ~~the~~ its costs of enforcement, including, but not limited to, sewage ~~disposal treatment~~ system repair, replacement, and/or maintenance, any administrative overhead, salaries, and expenses incurred by the following departments: ~~Public Department of Health and Human Services Branch, Community Development Services Planning and Building Department~~, County Counsel, Code Enforcement Unit, District Attorney, ~~Building~~, and/or Public Works Department. All such costs shall be a lien upon the property upon which the system is located. (Ord. 2159, § 3, 02/10/1998; (Ord. 2374, § 1, 12/05/2006; Ord. _____, § __, __/__/2017)

616-6. PROVISIONS CUMULATIVE.

The provisions of this article are in addition to any other requirements for a permit for construction, alteration, or repair of a sewage ~~disposal treatment~~ system. (Ord. _____, § __, __/__/2017)

CHAPTER 7GRAYWATER SYSTEMS617-1. DESIGN, CONSTRUCTION, AND PERMITTING.

Graywater systems shall be designed, constructed and permitted in accordance with Chapter 15 Alternate Water Resources for Nonpotable Applications, §§ 1501 through 1502.15 of the 2016 California Plumbing Code, as may be amended from time to time, which is incorporated herein in full. A Clothes Washer System as defined in § 1502.1.1 of Chapter 15 Alternate Water Sources for Nonpotable Applications of the 2016 California Plumbing Code does not require a permit to construct. Simple Systems and Complex Systems as defined in §§ 1502.1.2 and 1502.1.3 of Chapter 15 Alternate Water Sources for Nonpotable Applications of the 2016 California Plumbing Code require permits issued by the Health Officer, as well as construction permits issued by the County Building Official. (Ord. _____, § __, __/2017)

TITLE VI - WATER AND SEWAGE

DIVISION 2

SEWAGE AND ~~CESSPOOL~~-CLEANING

Chapter 1 - Regulation of the Business of Cleaning Cesspools, Septic Tanks, Seepage Pits, Pit Privies, and Vaults.

- § 621-1. Engaging in Business.
- § 621-2. Permits.
- § 621-3. Application for Permit.
- § 621-4. Investigation of ~~Applicants~~ and Issuance of Permits.
- § 621-5. Areas of Regulation.
- § 621-6. Expiration of Permits.
- § 621-7. Recourse of Faithful Performance Bond.

TITLE VI - WATER AND SEWAGE

DIVISION 2

~~SEWAGE AND CESSPOOL CLEANING~~

CHAPTER 1

REGULATIONS OF THE BUSINESS OF CLEANING CESSPOOLS, SEPTIC TANKS,
SEEPAGE PITS, PIT PRIVIES, AND VAULTS

621-1. ENGAGING IN BUSINESS.

The term "engaging in business of cleaning cesspools, septic tanks, seepage pits, pit privies and vaults and the removal of contents for cleaning thereof," as used herein, shall include, but is not limited, to any person who goes about from place to place with apparatus or equipment designed for cleaning cesspools, septic tanks, seepage pits, pit privies, and vaults, or who shall have an established place of business for said purpose and who shall make a charge for said services. (Ord. 245, § 2, 5/1/48; Ord. _____, § __, __/ /2017)

621-2. PERMITS.

No person shall engage in the business of cleaning cesspools, septic tanks, seepage pits, pit privies, and vaults and the removal of the contents thereof within the County without first having obtained from the Department of Health and Human Services, Division of Environmental Public Health, Branch a permit to do so as hereinafter provided. (Ord. 245, § 3, 5/1/48; Ord. 2351, § 22, 12/06/2005; Ord. _____, § __, __/ /2017)

621-3. APPLICATION FOR PERMIT.

All persons who desire to engage in the business of cleaning cesspools, septic tanks, seepage pits, pit privies, and vaults and the removal of the contents thereof within the County will make and file within the Department of Health and Human Services, Division of Environmental Public Health, Branch a written application for a permit to do so. (Ord. 245, § 3, 5/1/48; Ord. 2351, § 22, 12/06/2005; Ord. _____, § __, __/ /2017)

621-4. ~~INVESTIGATION OF APPLICANTS AND~~ ISSUANCE OF PERMITS.

It shall be the duty of the Department of Health and Human Services, Division of Environmental Public Health Branch of the County of Humboldt, upon receiving an application for a permit as herein provided, to investigate the ~~character of the applicant~~ applicant's knowledge of sanitary principles; the kind and type of apparatus and equipment ~~he~~ the applicant intends to use in cleaning cesspools, septic tanks, seepage pits, pit privies, and vaults; the place or places to which the contents of any cesspool, septic tank, seepage pit, pit privy, or vault may be removed; and, if the Department of Health and Human Services, Division of Environmental Public Health, Branch is satisfied from said investigation, to issue a permit to the applicant upon the payment of a fee for each permit issued in the amount set by resolution or ordinance of the Board of Supervisors and the giving of a personal or surety bond in the sum of ~~One Five Thousand Dollars (\$1,000.00)~~ (\$5,000.00) conditioned for the faithful performance of all duties enjoined by this division or by the Department of Health and Human Services, Division of Environmental Public Health Branch. (Ord. 1192, § 1, 2/7/78; Ord. 2351, § 22, 12/06/2005; Ord. _____, § __, __/ /2017)

621-5. AREAS OF REGULATION.

Every person who obtains a permit provided for in this division shall be subject to the rules and order of the Department of Health and Human Services, Division of Environmental Public Health, Branch in the following matters: (Ord. 2351, § 23, 12/06/2005; Ord. _____, § __, __/ /2017)

(a) The manner of cleaning any cesspool, septic tank, seepage pit, pit privy, or vault. (Ord. _____, § __, __/ /2017)

(b) The removal of the contents thereof and the place to which said contents are moved.

Refusal by any person to obey and carry out the rules and orders of the Department of Health and Human Services, Division of Environmental Public Health, Branch in the manner herein specified shall be grounds for the revocation of the permit referred to in this division. (Ord. 245, § 6, 5/1/48; Ord. 2351, § 22, 12/06/2005; Ord. _____, § __, __/ /2017)

621-6. EXPIRATION OF PERMITS.

Permits issued pursuant to this division shall be valid only for the unexpired portion of the calendar year in which the application is made. All permits shall expire and become null and void at the end of each calendar year. Permits may be renewed from year to year upon filing of a written application, the payment of the fee, and the giving of the faithful performance bond as provided for in § 621-4 of this chapter. (Ord. 989, § 1, 7/23/74)

621-7. RECOURSE TO FAITHFUL PERFORMANCE BOND.

In the event that the holder of a permit issued pursuant to the provisions of this division violates any of the provisions hereof or any rules or orders of the Department of Health and Human Services, Division of Environmental Public Health Branch, said violation shall permit the County at its option to resort to the faithful performance bond for the payment of a penalty in the sum of One Five Thousand Dollars ~~(\$1,000.00)~~ (\$5,000.00). (Ord. 245, § 8, 5/1/48; Ord. 2351, § 22, 12/06/2005; Ord. _____, § __, __/ /2017)

Appendix 3: SWRCB Water Quality Control Policy for Siting, Design, Operation, and Maintenance of Onsite Wastewater Treatment Systems.

Available online at:

https://www.waterboards.ca.gov/water_issues/programs/owts/docs/owts_policy.pdf